





Elmatic EM Servo Installation and User Guide

Thank you for choosing ELMATIC EM series multi-function, high performances general servo drives.

before you install, operate, maintain or inspect the servo drive, you must have read through this installation guide carefully and can use the equipment correctly. make full use the function of the servo drive, ensure the safety of the user.

In this installation guide, the safety instruction levels are classified into "WARNING" and "CAUTION". pay attention to the symbol " warning" " caution" and the related information.

" warning" indicates that incorrect handling may cause hazardous conditions, resulting in death or severe injury.

" caution" indicates that incorrect handling may cause hazardous conditions, resulting in medium or slight injury to personnel or may cause physical damage.

Map showing the instructions for use, is to facilitate the description, slightly different, refer to the actual product.

Please pay attention to the instructions given to the final user hand, and keep it for future maintenance and maintenance use.

If you have any questions, please contact with the company or agent of the company made contact, we will serve for you.

CONTENTS

CHAPTER 1 Panel operator	6
1.1 The nameplate of servo unit.....	6
1.2 The general specifications of servo unit.....	7
1.3 Installation of the servo unit	10
1.4 Servo drives' dimensions list	13
CHAPTER 2 Electrical wiring(DB15 servo)	16
2.1 Electrical wiring	16
2.2 Standard wiring of control mode	21
2.3 Wiring port definition(200W-3kW).....	27
2.4 Wiring port definition(4.5kW-18.5kW).....	31
2.5 Connector port circuit.....	35
CHAPTER 3 Panel operator	40
3.1 Panel operator's functions.....	40
3.2 Operating in the auxiliary function mode	40
3.3 Operation in the user parameter setting mode.....	41
3.4 Operation in the monitoring mode.....	43
CHAPTER 4 Motor self-learning	46
4.1 Motor angle self-learning	46
4.2 Load inertia self-learning.....	47
CHAPTER 5 Operation	49
5.1 Trial operation	49
5.2 Position control mode selection.....	50
5.3 Speed control mode running	54
5.4 Torque control mode running	58
CHAPTER 6 Parameters list.....	64

6.1 User parameters.....	64
Chapter 7 Communication Protocol.....	99
7.1 Selection of MODBUS parametes.....	99
7.2 MODBUS protocol.....	99
7.3 MODBUS applied example.....	100
Chapter 8 Maintenance and Inspection	101
8.1 Abnormality diagnosis and treatment measures.....	101
Chapter 9 Motor Adaptation Table.....	108
Chapter 10 Appendices((DB15 servo).	114

Tips:The main body of this manual is DB15 servo,DB9 servo wiring and defintion is written in the appendix.

CHAPTER 1 Specifications and the shape

1.1 The nameplate of servo unit

1.1.1 The nameplate of servo unit

Type:EMD100-40A-2 (00)

1.Driver series: EMD100:100 series

2.Driver power: 40A:400W; 75A:750W;100A:1KW; 150A:1.5KW;
200A:2KW; 300A:3KW; 400A:4KW; 500A:5KW; 600A:6KW; 750A:7.5
KW;11kA:11kW;15kA:15kW;18kA:18.5kW;

3.Driver voltage classes: 2:1PH/3PH AC220V; 4:3PH AC380V;

4.Software model: 00:Popular type;03:Fly shear;09:Rotary
knife;E:EtherCAT bus system;

1.1.2 The motor nameplate

Type:EMM- 60 KP 40A 30 D A Y Y B

1.Motor series

2. (Flange) : 60:60 flange; 80:80 flange;130:130 flange; 180:180 flange;

3.Inertia classes: KP: Low inertia; SP: Secondary inertia;

HP: High inertia;

4.Motor power: 40A:400W; 75A:750W;100A:1KW;

5.Motor rotate speed: 10: 1000rpm; 15: 1500rpm; 20:2000rpm;
25: 2500rpm; 30:3000rpm;

6.Encoder type: S:2500 wire(wireless);T:2500 wire(standard);

D:17 bit absolute value(Multi-turn);P:23 bit absolute value;

7.Electromagnetic brake: A: Without brake; B:With brake;

8.Keyway: Y:With keyway;

9.Oil seal: Y:With oil seal;

10. Voltage classes: B:220V; D:380V;

1.1.3 The power line

Type:EMC-DL 040-A-3(-T)

1.JIQU driver

2.Power line

3.Motor power: 020:200W; 040:400W; 075:750W; 100:1KW;

150:1.5KW; 200:2KW; 300:3KW; 450:4.5KW; 550:5.5KW; 750:7.5KW

4.Joint: A:Fast palstic joint; H:Avi`ation joint; F: Water joint;

5.Length: 3:3M; 5:5M; 7:7M; 10:10M;

6.Flexible catanary

1.1.4 Encoder line

Type:EMC-BM 040 S-A -3 (-T)

1.JIQU driver

2.Encoder line

3.Motor power: 020:200W; 040:400W; 075:750W; 100:1KW;

150:1.5KW; 200:2KW; 300:3KW; 450:4.5KW; 550:5.5KW; 750:7.5KW

4.Encoder type: B:2500 wire(standard); 2500 wire(wireless);J:17 bit/23 bit

5.Joint: A:Fast palstic joint; H:Aviation joint; F: Water joint;

6.Length: 3:3M; 5:5M; 7:7M; 10:10M;

7.Flexible catanary

1.2 The general specifications of servo unit

The general specifications	Control mode		1.Position control 2.Speed control 3.Torque control
	Feedback type		1. Incremental square wave 2. Absolute value
	Conditions of use	Using/Storage temperature	0 ~ +55°C/20 ~ +85°C
		Using/Storage humidity	90%RH or less(non-condensing)
Resistance to vibration/impact resistance		4.9m/s ² /19.6m/s ²	

Speed-Torque control mode	Performance	Speed control scope		1: 5000(The lower limit of the speed control range is the condition of not stopping in rated torque load)
		Speed changing rate	Load changing rate	When the load is 0 ~ 100%: less than $\pm 0.01\%$ (in the rated speed)
			Voltage changing rate	Rated voltage $\pm 10\%$: 0%(in the rated speed)
			Temperature changing rate	$25 \pm 25^\circ\text{C}$: less than $\pm 0.1\%$ (in the rated speed)
		Frequency characteristics(bandwidth)		1.3KHz(when $J_L = J_M$)
		Torque control precision (reproducibility)		$\pm 2\%$
		Soft start time setting		0 ~ 65s(can respectively set acceleration and deceleration time)
Speed-Torque control mode	Input signal	Speed instruction input	Instruction voltage	DC $\pm 10\text{V}$ (DC 0V ~ $\pm 10\text{V}$: Variable setting range)/rated rotating speed Input voltage: maximum $\pm 12\text{V}$ (Motor forward when the instruction is positive)
			Input impedance	About 10k Ω
			The circuit time parameter	About 47 μs
		Torque instruction input	Instruction voltage	DC $\pm 10\text{V}$ (DC 0V ~ $\pm 10\text{V}$: Variable setting range)/rated rotating speed Input voltage: maximum $\pm 12\text{V}$ (Motor forward when the instruction is positive)
			Input impedance	About 10k Ω
			The circuit time parameter	About 47 μs
		Torque speed command	Selection of the rotating direction	Input using DI signal

Position control model	Performance	Feedforward compensation		0 ~ 100%(Setting resolution 1%)	
		Positioning complete width setting		1 ~ 65535 Command unit(Setting resolution 1 Command unit)	
	encoder	Incremental	2500wire,5000wire wire-saved		
		Absolute value	17bit,20bit,23bit		
	Input signal	Command pulse	Input pulse kinds	1.Symbol+pluse sequence 2.CCW+CW pluse sequence 3.90°Phase difference 2-phase pulse(A phase+B phase)	
			Input pulse state	Differential drive (+ 5V level) Open Collector(+5V, +12Vor +24V level)	
			Input pulse frequency	Differential drive: maximum 4MHz Open collector drive: maximum 500kHz	
		Control signal		Clear signal (input pulse shape and make pulse the same)	
	Input output signal	Position output	Output state		A phase、 B phase、 Z phase、 Differential driver Output
Divide ratio			Arbitrarily divide		
Input signal sequentially		Can conduct signal distribution's change		9 road DI	
				Servo ON, P action (or control mode switching, motor's forward /reverse switch carried by the internal speed , zero phase, prohibit command pulse), prohibits forward drive (P-OT), prohibiting reverse drive (N -OT), alarm reset, the forward current limiting, reverse side current limit (or internal speed selection)	
Output signal sequentially		Can conduct signal distribution's change		5 road DO	
	Contain positioning complete (consistent speed), the rotating motor, servo ready, current limit, the speed limit, the release of the brake warning, NEAR signal				

Built-in functions	Dynamic brake (DB) function		The main power OFF, servo alarm, servo OFF, overtravel action
	Overtravel (OT) prevention function		P-OT, N-OT action when DB stops, deceleration stop or coasting stop
	Electronic gear		$0.001 \leq B/A \leq 4000$
	Prevention function		Overcurrent, overvoltage, undervoltage, overload, abnormal regeneration, the main circuit detection is not unusual, fin overheat, loss phase of power supply, overflow, overspeed, encoder error, to prevent runaway, CPU abnormalities, abnormal parameters, position offset, others
	LED display function		Main power CHARGE, 5 LED display
	Communication function	Connected devices	CAN(sybase), MODBUS
		Axis address setting	Set according to user parameter
		1: N communication	When the RS-485 port, the largest slave station is decided by master station's number
		Function	Status display, the user parameter settings, monitor display, alarm trace display, JOG operation and auto-tuning operation, speed, torque command signal, such as mapping functions
	Others		Origin search, motor angle self-learning function, gain self-adjustment, low-frequency vibration suppression, running mode switchover, motor suppressing resonance, abundant DIDO functions, full-closed loop control, interrupt fixed length function, easy to install and maintain, the product has a complete range of power

1.3 Installation of the servo unit

EMD100 servo unit is the base type (applicable to shelving) servoamplifier. If you install in the wrong way, the fault will occur, so please install properly according to the following considerations.

1.3.1 The using environment

When in the unpowered state to keep the servo unit, for safekeeping in the temperature range $-20 \sim +85$ °C, and no condensation at 90% RH or less.

- Overvoltage category: III
- Defacement degree: 2
- The degree of protection: 1X
- Altitude: 1000m or less

according to the following criteria

- UL508C • CSA C22.2 No.14 • EN50178
- EN55011 group 1 class A • EN61000-6-2

1.3.2 Installation place

◆ Installed in the control cabinet, designing the control cabinet size, the configuration of the servo unit and cooling method so that the peripheral portion of the servo unit is at a temperature below 55 °C.

◆ When installed in the vicinity of the heating element, the temperature of the servo unit is maintained below around 55 °C, please control the warming due to heat radiation or convection caused by the heating element.

◆ Installed near the vibration source. Please install vibration isolator on the surface of servo unit to prevent vibration transmission to the servo unit.

◆ When installed in corrosive gases place, try to prevent the intrusion of corrosive gases. Although no immediate impact, but will lead to fault of electronic components and the fault of related components of contactors.

1.3.3 Mounting direction

As shown below, the direction perpendicular to the direction of installing wall. Using self-convection or fan cooled servo unit. Be sure to observe the direction of the installation requirements. Please Using 2 ~ 4 (installed holes varies due to the capacity) mounting holes of the servo

unit is securely fixed to the mounting surface.

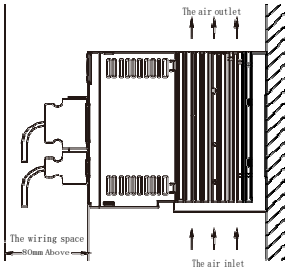

1.3.4 The installation standard

Be sure to comply with the installation standard in the control cabinet as shown in the figure, the standard adapted to multiple servo units mounted side by side in the control cabinet occasions (referred to "side by side installation"below).

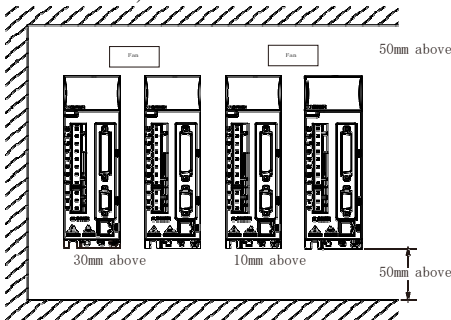

◆ The servo unit's toward

When installing, make positive servo unit (actual mounting surface of the panel operator) for the operator, and make it perpendicular to wall.

◆ Cooling

To ensure it can be cooled by natural convection fan, please refer to the figure, leave enough space around the servo unit.

◆ When installed side by side observe the direction of the installation requirements. Please Using 2 ~ 4 (installed holes varies due to the capacity) mounting holes of the servo unit is securely fixed to the mounting surface.

1.4 Servo drives' dimensions list

1.4.1 SIZE A dimensions

Suitable Model: Under 750W

Width × height × depth=168×168×45mm

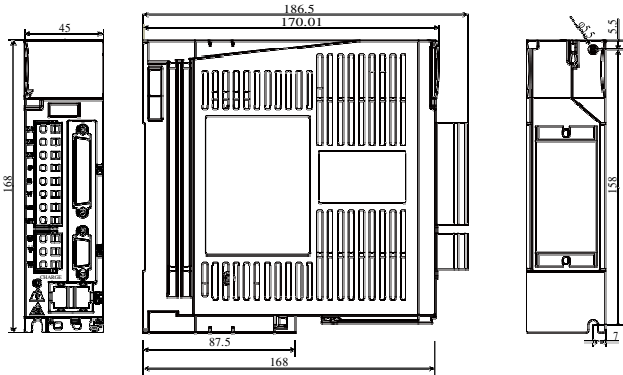

1.4.2 SIZE B dimensions

Suitable Model: 220V 1kW-2kW / 380V 2KW-3KW

Width × height × depth=168×168×70mm

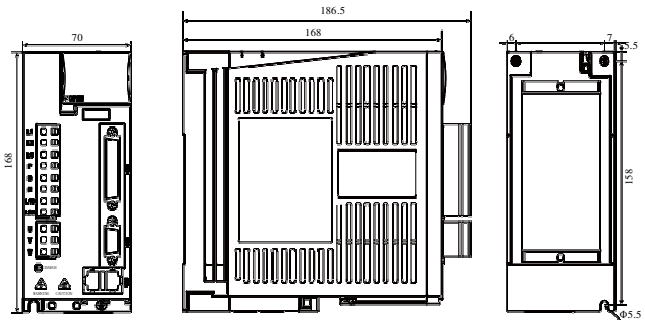

1.4.3 SIZE C dimensions

Suitable Model: 4.5kW-5.5kW

Width×height×depth=260×200×88.5mm

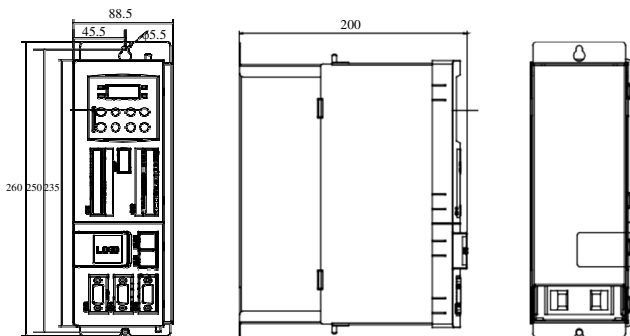

1.4.4 SIZE D dimensions

Suitable Model: 7.5kW-11kW

Width×height×depth=290×202×135.5mm

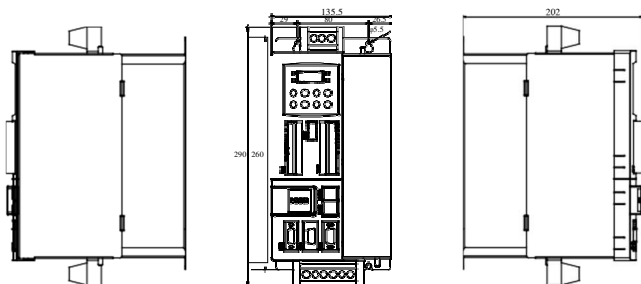

1.4.5 SIZE E dimensions

Suitable Model: 15kW-18.5kW

Width×height×depth=290×222×192.5mm

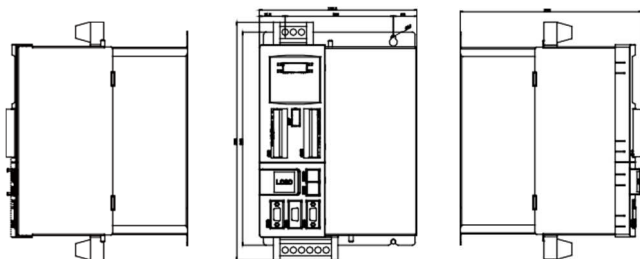

CHAPTER 2 Electrical wiring

2.1 Main circuit wiring

- Do not pass power lines and signal lines through the same pipeline through, and do not banding together. When wiring, power lines and signal lines should leave more than 30cm. Otherwise, it may result in malfunction.

- Signal line、encoder (PG) feedback lines use stranded wire and multi-core shield wire. For the wiring length, the command input line up to 3m, encoder feedback line up to 20m.

- Even if the power is turned off, the servo unit may remain high voltage. Within five minutes, do not touch the power terminals. Please confirm CHARGE lamp goes out before further inspection operations.

- Do not frequently switch the power supply. When you need to repeatedly continuously switch power supply, control one minute one time or less. Since servo unit's power with a capacitance, so when the power is on, there will be large charging current flowing through (charging time 0.2 seconds). Therefore, if frequently switch the power supply, it will reduce the performance of the main circuit element inside the servo unit.

2.1.1 The main circuit power connector (spring) wiring method

The servo unit below 1.5kW capacity with the main circuit power supply terminal and the control power supply terminal with removable connector. Follow the steps below for the power connector wiring.

(1) Wire Size

Wire sizes that may be used are as follows. Strip the wire jacket to use.

- A single line..... $\Phi 0.5 \sim \Phi 1.6$ mm
- Stranded wire.....AWG28 \sim AWG12

(2) Connection methods

1. Strip the skin of using wire.

2. Use the tool opening portion in the power connector wire insertion.

- Openings include two kinds of methods A and B

- In the case of A map, hang incidental rod of servo unit to open portion.

- In the case of B map, chart by a slotted screwdriver (blade width of 3.0 ~ 3.5mm)

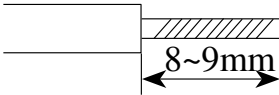

3. The core wire partially inserted in the opening, After insertion, release the lever or a slotted screwdriver.

- When wiring, remove the power connector from the body of the servo unit.

- A port of electric power supply connector is inserted only one wire.

- When inserting wires, Please do not make the core wire and the adjacent electrical short circuit.

legendA

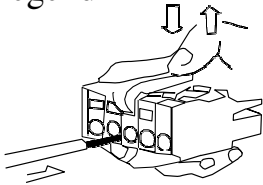

legendB

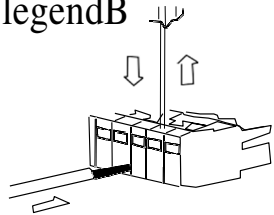

2.1.2 Typical examples of the main circuit wiring

(1) Three phase 380V wiring

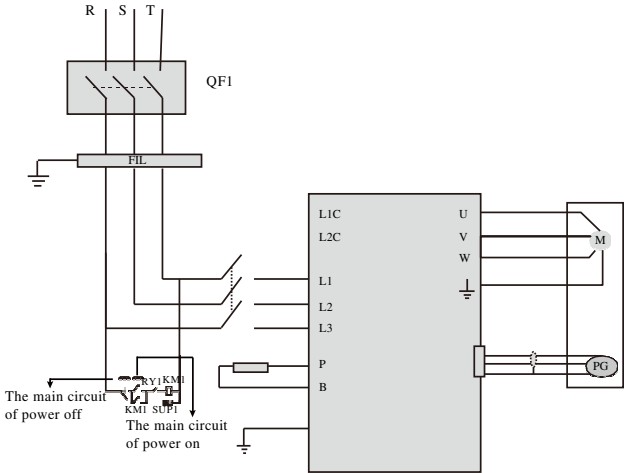

QF1: Circuit breaker

RY1:Relay FIL:

Noise filter PL1:

Display lamp SUP1

: Suppressor

KM1: Magnetic contactor

(2) Single phase 220V wiring

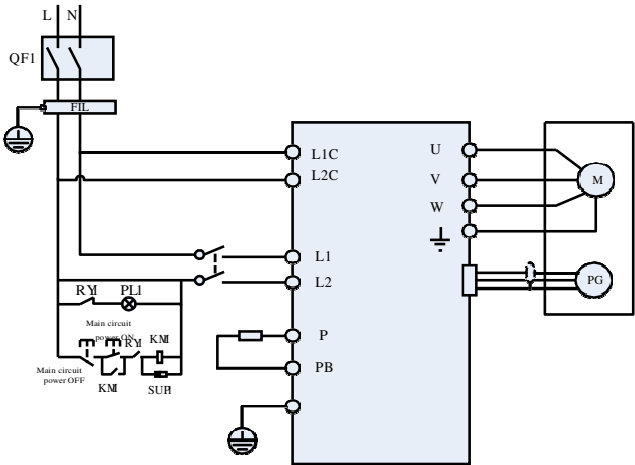

QF1: Circuit breaker

RY1: Relay FIL:

Noise filter PL1:

Display lamp SUP1

: Suppressor

KM1: Magnetic contactor

(3) Three phase 220V wiring

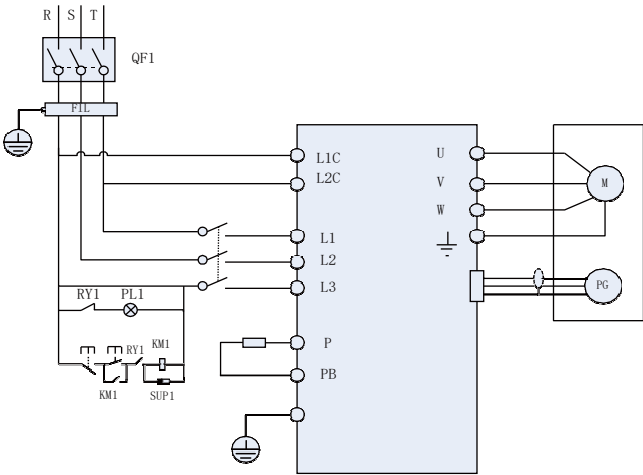

QF1: Circuit breaker

RY1:Relay FIL:

Noise filter PL1:

Display lamp SUP1

: Suppressor

KM1: Magnetic contactor

Important note:

Because of the shafts of motor and encoder are coupled,so please don't strike it when install belt wheel or connecting shaft at motor shaft. If not,the encoder will be damaged.(This situation is out of warranty coverage)

2.2 Standard wiring of control mode

2.2.1 Speed control mode(200W-3kW)

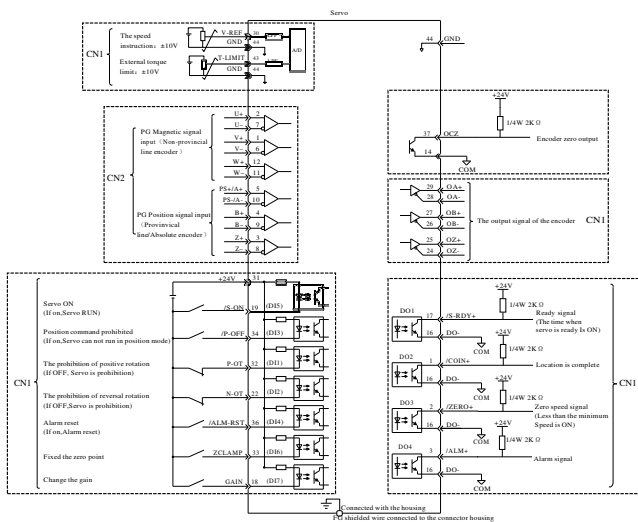

2.2.2 Speed control mode(4.5kW-18.5kW)

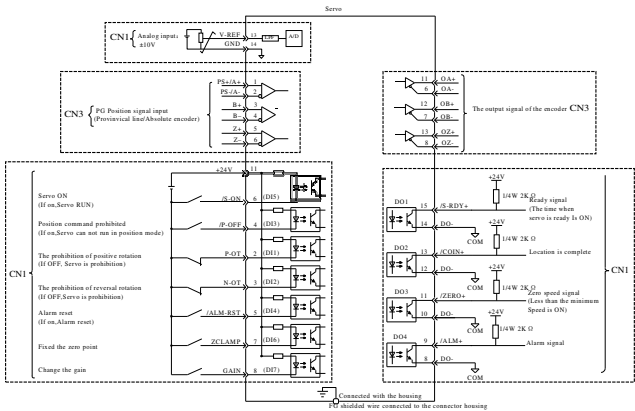

2.2.3 Position control mode(200W-3kW)

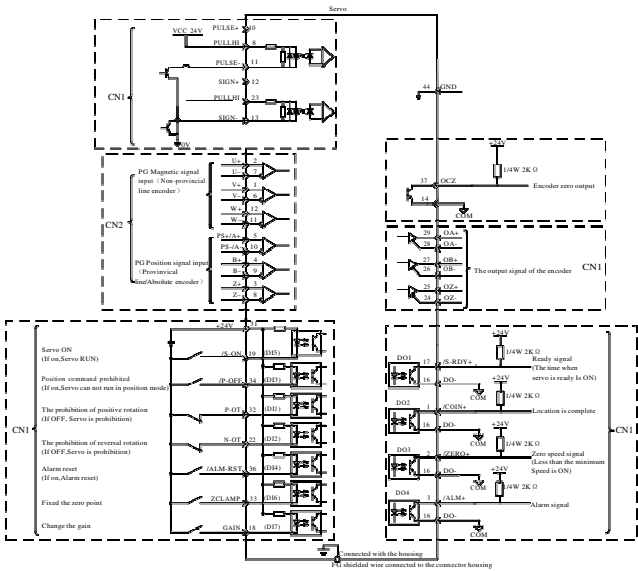

2.2.4 Position control mode(4.5kW-18.5kW)

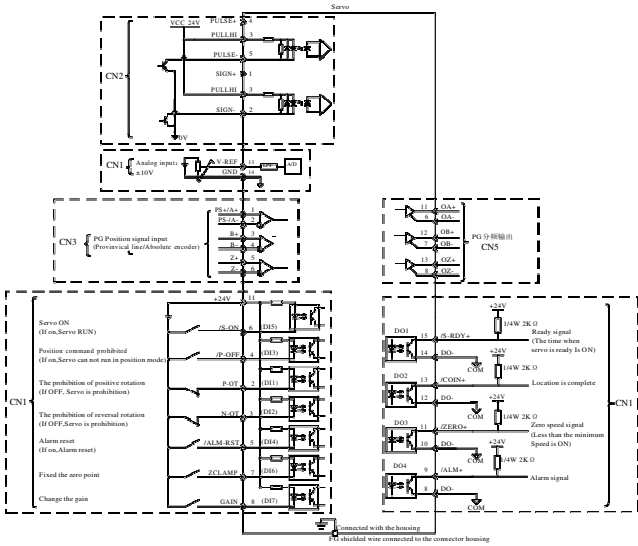

2.2.5 Torque control mode(200W-3kW)

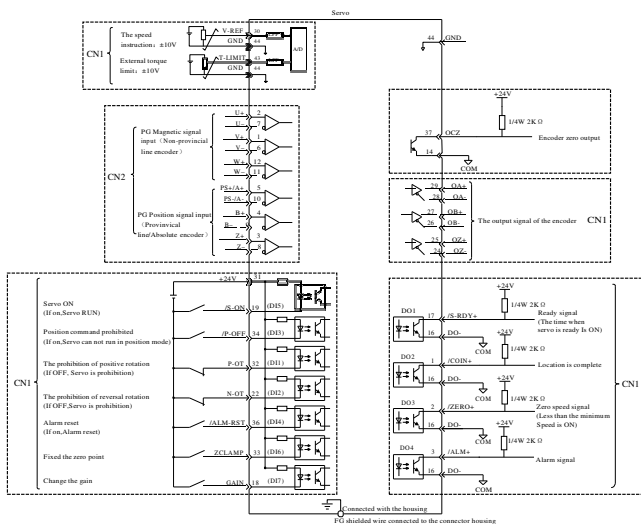

2.2.6 Torque control mode(4.5kW-18.5kW)

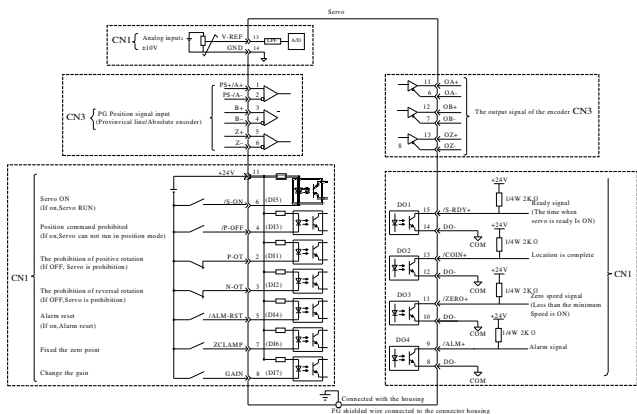

2.3 Wiring port definition(200W-3kW)

2.3.1 Strong power terminals instructions

Terminal symbol	Signal Name	Function
L1	The main circuit power input single-phase or three-phase interface terminal	187V - 242V(-15% ~ 10%) 50/60Hz The maximum inrush current is 20A.
L2		
L3		
U	Servo motor connection terminals	Connect correspondingly to servo motor's U, V, W
V		
W		
L1C	The control circuit power input terminal	Single-phase AC200V ~ 230V (-15 ~ +10%) 50Hz/60Hz
L2C		
PB	External regenerative resistor connection terminals	Server built-in regenerative resistor, so the factory must disconnect between B-P, insufficient regeneration ,connect an external regenerative resistor between B-P.Please purchase external regeneration resistor separately.
P		

2.3.2 Input and output signal connection (CON1) terminal definition

Pin number of interface terminal	Signal Name	Function Description	Pin number of interface terminal	Signal Name	Function Description
1	DO2+	Digital signal 2 output +	2	DO3+	Digital signal 3 output +
3	DO4+	Digital signal 4 output +	4	DO5+	Digital signal 5 output +
5	DO6+	Digital signal 6 output +	6	DO7+	Digital signal 7 output +
7	DO8+	Digital signal 8 output +	8	PULLHI	Instruction pulse outside source's input interface
9	COM-	Interior 24V power GND	10	PULSE+	Instruction pulse input +
11	PULSE-	Instruction pulse input -	12	SIGN+	Instruction symbol input +
13	SIGN-	Instruction symbol input -	14	GND	Common ground
15	+24V	Interior 24V power positive	16	DO1-	Digital signal 1 output -
17	DO1+	Digital signal 1 output +	18	DI7-	Digital signal 7 input -
19	DI5-	Digital signal 5 input -	20	DI9-	Digital signal 9 input -

21	DI8-	Digital signal 8 input -	22	DI2-	Digital signal 2 input -
23	PULLHI	Open-collector output interior +24V	24	PZO-	PG frequency division output Z signal-
25	PZO+	PG frequency division output Z signal +	26	PBO-	PG frequency division output B signal-
27	PBO+	PG frequency division output B signal +	28	PAO-	PG frequency division output A signal-
29	PAO+	PG frequency division output A signal+	30	AI2	Analog 2 input
31	COM+	External 24V power	32	DII-	Digital signal 1 input -
33	DI6-	Digital signal 6 input -	34	DI3-	Digital signal 3 input -
35			36	DI4-	Digital signal 4 input -
37	OCZ	Encoder zero point output	38	+5V	5V power+
39	HSIGH-	High speed pulse instruction symbol input -	40	HSIGH+	High speed pulse instruction symbol input +
41	HPULSE-	High speed pulse instruction input -	42	HPULES+	High speed pulse instruction input +
43	AI1	Analog 1 input	44	GND	Common ground

(NOTE)Please make input and output signals connect to the connector with cable shielding,Servo unit side connects to the FG (frame ground)

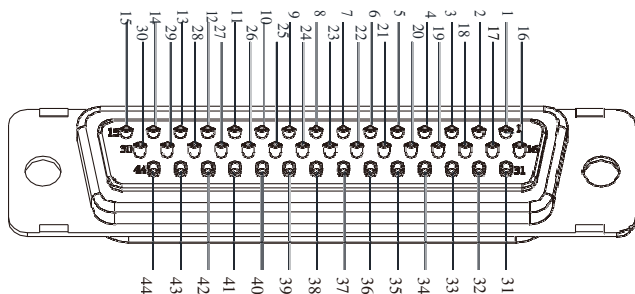

2.3.3 Feedback signal connection (CN2) terminal definition

2.3.3.1 Provincial line increment encoder interface definition

Pin number of interface terminal	Signal name	Function description	Pin number of interface terminal	Signal name	Function description
----------------------------------	-------------	----------------------	----------------------------------	-------------	----------------------

1			2		
3	PGZ+	Differential signal Z signal +	4	PGB+	Differential signal B signal +
5	PGA+	Differential signal A signal +	6		
7			8	PGZ-	Differential signal Z signal -
9	PGB-	Differential signal B signal -	10	PGA-	Differential signal A signal -
11			12		
13	+5V	5V power +	14	GND	Common ground
15					

2. Bus-type encoder interface definition

Pin number of interface terminal	Signal name	Function description	Pin number of interface terminal	Signal name	Function description
1			2		
3			4		
5	PS+	Bus differential signal input +	6		
7			8		
9			10	PS-	Bus differential signal input -
11			12		
13	+5V	5V power	14	GND	Common ground
15					

Note:Shield wire should be connected to the metal casing.

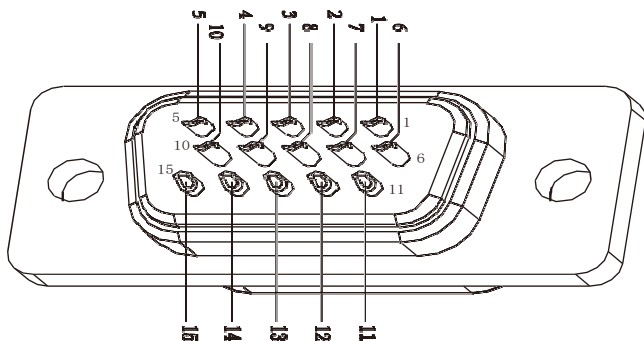

2.3.4 Communication signal connection (CN3) terminal definitions

Pin number of interface terminal	signal name	Function description	Pin number of interface terminal	signal name	Function description

1	RS232R	RS232 receiving line	2	RS232T	RS232 output line
3	RS485+	RS485+ insert	4	RS485-	RS485- insert
5	GND	Ground	6	NC	-
7	NC	-	8	GND	Ground

2.4 Wiring port definition(4.5kW-18.5kW)

2.4.1 Strong power terminals instructions

Terminal symbol	Signal Name	Function
R	The main circuit power input single-phase or three-phase interface terminal	323V - 418V(-15% ~ 10%) 50/60Hz The maximum inrush current is 20A.
S		
T		
U	Servo motor connection terminals	connect correspondingly to servo motor's U, V, W
V		
W		
-	Bus Voltage -	
PB	External regenerative resistor connection terminals	Connect an external regenerative resistor ;
+		

2.4.2 Input and output signal connection (CN1、CN2、CN5) terminal definition

1) CN1

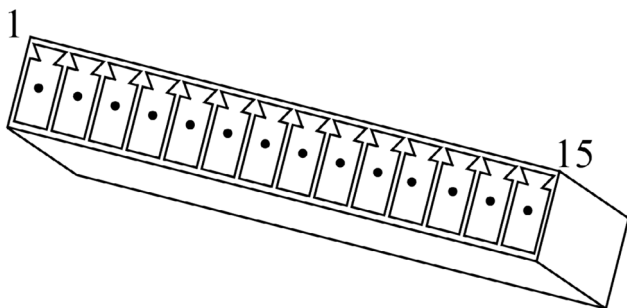

pin number of interface terminal	signal name	Function description	pin number of interface terminal	signal name	Function description
1	COM-	outside 24V power GND	2	DI1	Digital signal 1 input
3	DI2	Digital signal 2 input	4	DI3	Digital signal 3 input
5	DI4	Digital signal 4 input	6	DI5	Digital signal 5 input
7	DI6	Digital signal 6 input	8	DI7	Digital signal 7 input
9	DI8	Digital signal 8 input	10	DI9	Digital signal 9 input
11	COM+	outside 24V power	12	24V+	interior 24V power positive
13	AI1	Analog 1 input	14	GND	GND
15					

2)CN2

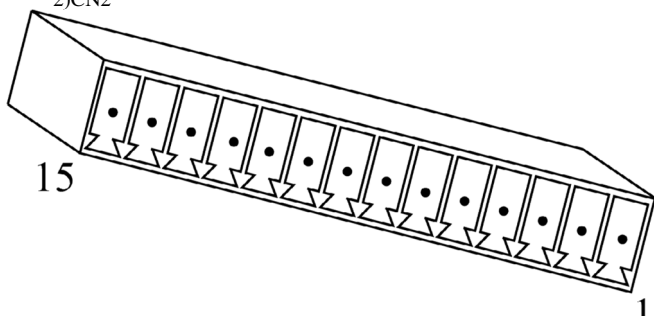

pin number of interface terminal	signal name	Function description	pin number of interface terminal	signal name	Function description
1	SIGN+	Instruction symbol input +	2	SIGN-	Instruction symbol input -
3	PULLHI	Open-collector output interior 24V	4	PULSE+	Instruction pulse input +
5	PULSE-	Instruction pulse input -	6	DO5-	Digital signal 5 output -
7	DO5+	Digital signal 5 output +	8	DO4-	Digital signal 4 output -
9	DO4+	Digital signal 4 output +	10	DO3-	Digital signal 3 output -

pin number of interface terminal	signal name	Function description	pin number of interface terminal	signal name	Function description
11	DO3+	Digital signal 3 output +	12	DO2-	Digital signal 2 output -
13	DO2+	Digital signal 2 output +	14	DO1-	Digital signal 1 output -
15	DO1+	Digital signal 1 output +			

3)CNS

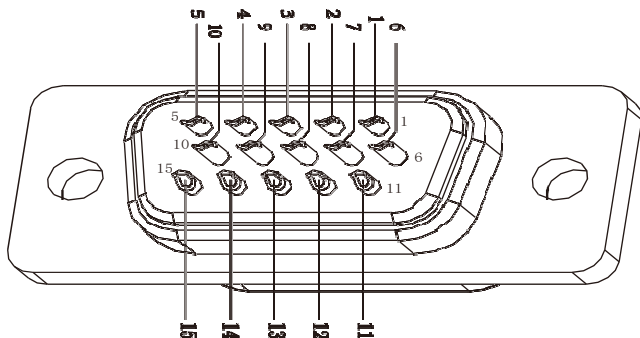

pin number of interface terminal	signal name	Function description	pin number of interface terminal	signal name	Function description
1	HPULSE-	High speed pulse instruction input -	2	HPULSE+	High speed pulse instruction input +
3	HSIGN-	High speed pulse instruction symbol input -	4	HSIGN+	High speed pulse instruction symbol input +
5	GND	GND	6	PAO-	PG frequency division output A signal -
7	PBO-	PG frequency division output B signal -	8	PZO-	PG frequency division output Z signal -
9	NC	Not Connected	10	NC	Not Connected
11	PAO+	PG frequency division output A signal +	12	PBO+	PG frequency division output B signal +
13	PZO+	PG frequency division output Z signal +	14	GND	GND
15	+5V	5V Power +			

2.4.3 Feedback signal connection (CN3) terminal definition

Pin number of interface terminal	Signal name	Function description	Pin number of interface terminal	Signal name	Function description
1	PGA+	Differential signal A input +	2	PGA-	Differential signal A input -
3	PGB+	Differential signal B input +	4	PGB-	Differential signal B input -
5	PGZ+	Differential signal Z input +	6	PGZ-	Differential signal Z input -
7	+5V	5V power	8	GND	Power ground wire
9					

Note:Shield wire should be connected to the metal casing.

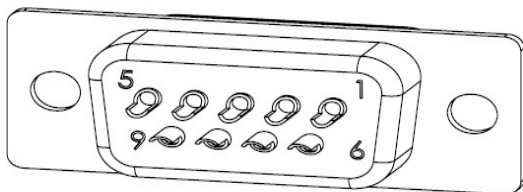

2.4.4 Communication signal connection (CN6、CN7) terminal definitions

Pin number of interface terminal	signal name	Function description	Pin number of interface terminal	signal name	Function description
1	RS232R	RS232 receiving line	2	RS232T	RS232 output line
3	RS485+	RS485+ insert	4	RS485-	RS485- insert
5	GND	Ground	6	CANH	CAN+ insert
7	CANL	CAN- insert	8	GND	Ground

2.5 Connector port circuit

Servo unit's input output signal and the instruction controller's connection example is as follows.

2.5.1 Wiring diagram(200W-3kW)

(1)Instruction input circuit's port.

1.Analog input circuit

CN1 connector's 30-44(the speed instruction input)、43-14(the torque instruction input) terminal

Analog signal is the speed instruction or the torque instruction signal,the input impedance is as follows.

The speed instruction input: about 14 kΩ

The speed command input:about 14 kΩ

The torque instruction input: about 14 kΩ

The input signal's maximum allowable voltage is 12V

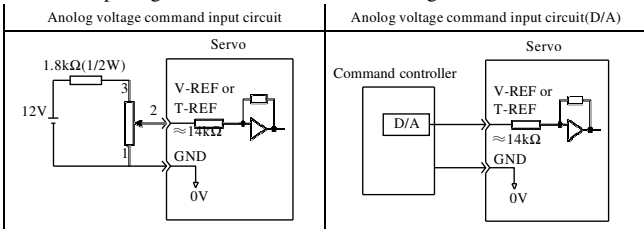

2.Position instruction input circuit

Command controller side's command pulse,offset pulse cleared

signal's output circuit, can output from the bus driver,open collector output (2 kinds).Classification is expressed as follows.

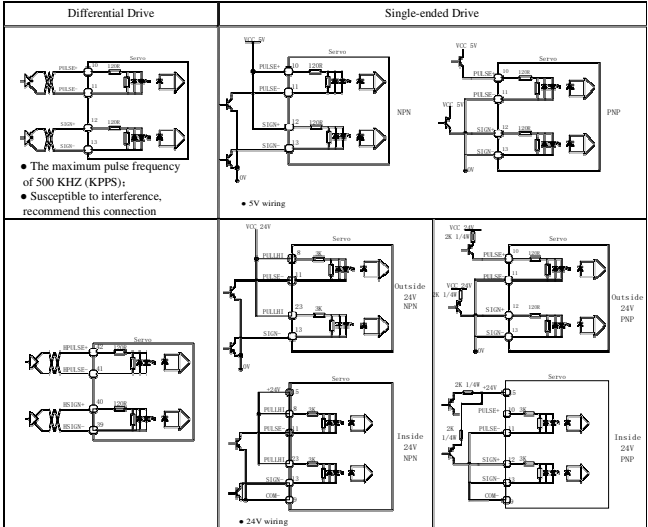

(2) The control input circuit's port

Explain CN1 connector's 32, 22, 34, 36, 19, 33, 18, 21, 20 terminal.Connected by a relay or open collector transistor circuit.The use of relay connection, select the micro current relay,if don't use the micro current relay,it will lead to poor contact.

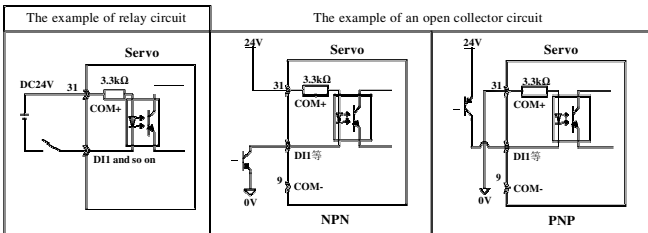

(3) Output circuit's connection port.

Servo unit's signal output circuit has the following 3 kinds.

1. Differential driver output circuit

Following, to explain the CN1 connector's 29-28(A phase signal)、27-26(B phase signal)、25-24(Z phase signal) signals.

Conduct 2 phase (A phase、B phase) transform output signal (OA+, OA-, OB+, OB-) for the encoder's serial data and the origin of the pulse signal (OZ+, OZ-) is output by the bus driver circuit. In general, use when the servo unit by speed control, constituting position control at the side of command controller. When at the side of command controller, please receive using the bus receiver circuit.

2. Photoelectric encoder's output circuit

Servo alarm (ALM)、servo ready (/S-RDY) and other output signals related with the output circuit signal, and is connected by the relay or the PLC receiver.

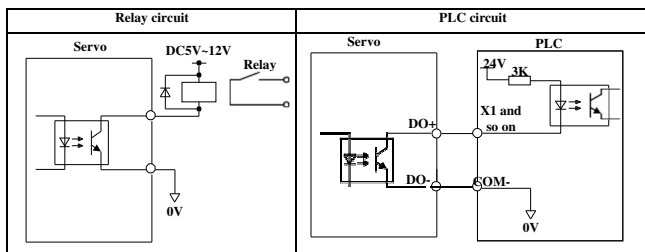

(NOTE) Photoelectric encoder's maximum allowable voltage、current capacity is as follows.

Maximum voltage: DC30V Maximum current: DC50mA

2.5.2 Wiring diagram (4.5kW-18.5kW)

(1) Instruction input circuit's port.

1. Analog input circuit

CN1 connector's 13-14 (the speed instruction input)、15-14 (the torque instruction input) terminal

Analog signal is the speed instruction or the torque instruction signal, the input impedance is as follows.

The speed instruction input: about 14 k Ω

The speed command input: about 14 k Ω

The torque instruction input: about 14 k Ω

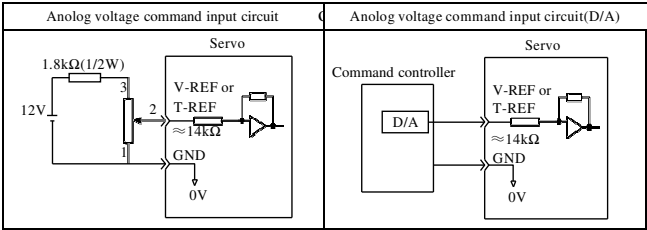

2.Position instruction input circuit

Command controller side's command pulse,offset pulse cleared signal's output circuit, can output from the bus driver,open collector output (2 kinds).Classification is expressed as follows.

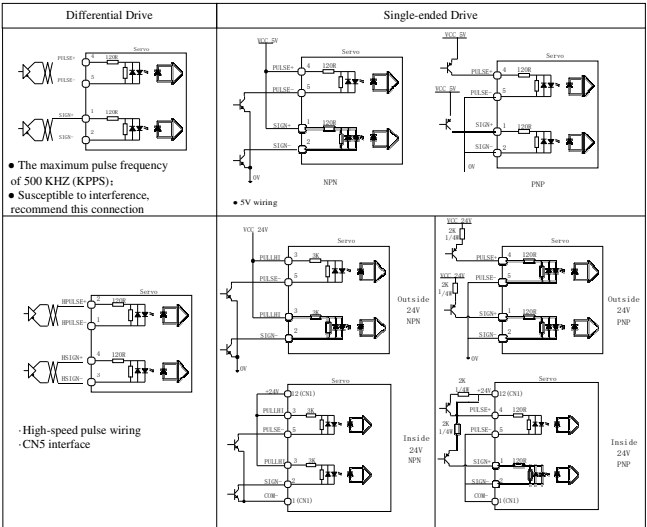

(2) The control input circuit's port

Explain CN1 connector's 2、3、4、5、6、7、9、10 terminal. Connected by a relay or open collector transistor circuit.The use of relay connection, select the micro current relay,if don't use the micro current relay.it will lead to poor contact.

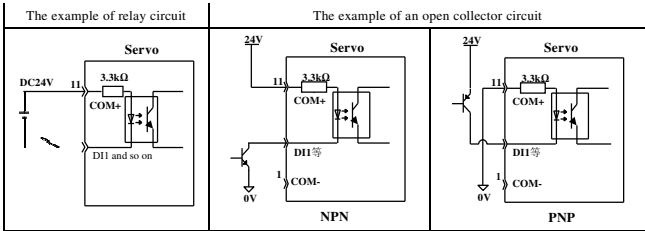

(3) Output circuit's connection port.

Servo unit's signal output circuit has the following 3 kinds.

1. Differential driver output circuit

Following, to explain the CN1 connector's 11-6(A phase signal)、12-7(B phase signal)、13-8(Z phase signal) signals.

Conduct 2 phase (A phase、B phase) transform output signal (OA+, OA-, OB+, OB-) for the encoder's serial data and the origin of the pulse signal (OZ+, OZ-) is output by the bus driver circuit. In general, use when the servo unit by speed control, constituting position control at the side of command controller. When at the side of command controller, please receive using the bus receiver circuit.

2. Photoelectric encoder's output circuit

Servo alarm (ALM)、servo ready (/S-RDY) and other output signals related with the output circuit signal, and is connected by the relay or the PLC receiver.

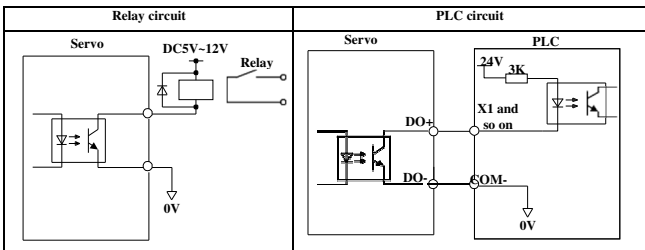

(NOTE) Photoelectric encoder's maximum allowable voltage、current capacity is as follows.

Maximum voltage: DC30V Maximum current: DC50mA







Chapter 3 Panel operator

3.1 Panel operator's functions

Panel operation can be used for various kinds of user parameters' setting, JOG running command's execution and status display.

3.1.1 Key's name and function

The following summarizes the names and the functions of each key.

Built-in panel operator	Functions
 MODE/SET	1. Used to switch the basic mode (status display mode, the auxiliary function mode, parameter setting mode, monitor mode). 2. used as digital setting key
 DATA	1. For displaying each user parameters' setting and the setting value
 (UP)	1. Pressing the UP key can increase the set value. 2. In JOG operation, used as a forward start key.
 (DOWN key)	1. Pressing the DOWN key can decrease the set value. 2. In JOG operation, used as a reverse start key.
 DATA (DATA/SHIFT key)	Press this button can move the selected bit (blinking) to the left a bit
 MODE/SET (MODE/SET key)	When in JOG operation carried out by the operator, used for servo ON / servo OFF.

3.2 Operating in the auxiliary function mode

3.2.1 Auxiliary function mode list

This part is using to explain the digital operator's operation of motor running and adjustment. The following shows the auxiliary function mode of the user parameter list and their functions.

User parameter number	Functions
P00	Servo driver parameters
P01	Servo basic control parameters

P02	Input terminal parameters
P03	Output terminal parameters
P04	Positioning control parameters
P05	Speed control parameters
P06	Torque control parameters
P07	Gain setting parameters
P08	System parameters self-learning
P09	Default and protection parameters
P0A	MODBUS communication parameters
P0B	System state display
P0D	Servo auxiliary control parameters
P0E	Full closed loop control parameters
P10	Multistage positioning control parameters
P11	Multistage speed control parameters

3.3 Operation in the user parameter setting mode

Can select or adjust function by setting the user parameters. User parameters have "parameters Setting" and "function selection" two types. User parameters setting is the function to adjust the parameters data within a certain range to change. function selection is to choose the function of every digit that already assigned to the panel operator.

3.3.1 User parameters setting

(1) Parameters setting

(a) The following shows the operating steps of the user parameter P07-00's contents (speed loop gain) from "25.0" change to "30.0".

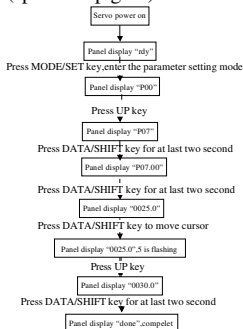

(b) This manual's user parameters representation

This manual describes the user parameters by the following format.

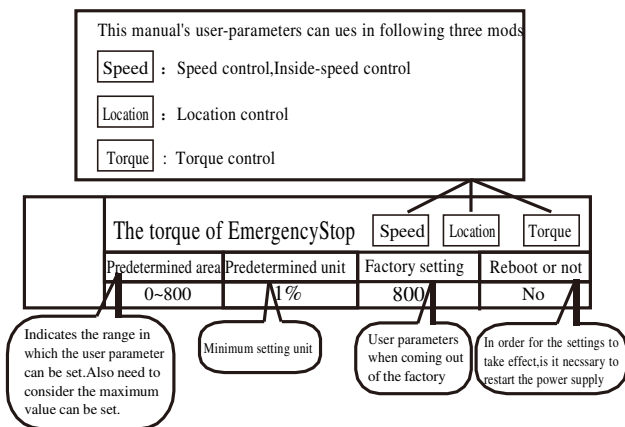

(2) Effective mode

(a) Effective mode description

Kind	Control power restart
Power on next time	YES
Immediately effect	NO

(b) Effective mode-power on next time change step example

The following shows the pluse instruction form changes from 0-pluse + direction to 2-AB.

(c) User display mode of this manual

<1>5 digits' nixie tube single page display, under 4 digits' signed number and under 5 digits' unsigned number. The example shows the following:



<2>5 Digits' nixie tube single page can't display, above 4 digits' signed number and above 5 digits' unsigned number. The example shows the following:



<3>Fault display



3.4 Operation in the monitoring mode

3.4.1 Monitoring mode display

(1) Display in the monitoring mode with input/output signal the example as follows

(a) The monitor display of input signal state

Display the input status of input terminal's signal assigned. When the input is OFF (open state), the upper display segment (LED) lights.

When the input is ON (short-circuit) state, the lower display segment (LED) lights.

Please confirm the relationship between the input terminal and input signal.

Display LED number	Input terminal's name	The factory setting
1	CN1-32	P-OT
2	CN1-22	N-OT
3	CN1-34	/INHIBIT
4	CN1-36	/ALM-RST
5	CN1-19	/S-ON

/S-ON signal is ON (make servo on with L level)

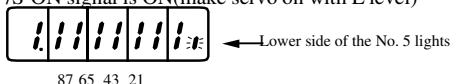

/S-ON signal is OFF

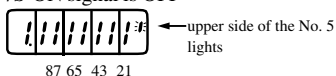

(b) Monitor display of the output signal state

Display the output status of input terminal's signal assigned. When the input is OFF (open state), the upper display segment (LED) lights.

When the output is ON (short-circuit) state, the lower display segment (LED) lights.

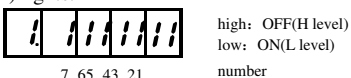

Display LED number	Input terminal's name	The factory setting
1	CN1-16、 17	/S-RDY
2	CN1-16、 1	/COIN
3	CN1-16、 2	/ZERO
4	CN1-16、 3	/ALM

The monitoring display of the output signal is the same as the monitoring display of the input signal, as described above, are allocated on the panel display. Output signal ON / OFF to ON (L-level) on the lower side, OFF (H-level) on the side of the display section lights for display.

S-RDY signal action (alarm performed by the H-level)

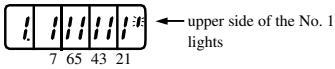

(2) Using methods in the monitoring mode

The following shows display step of monitoring number POB-00 data (Servo motor rotates at the speed of 3000min-1)

Chapter 4 Motor self-learning

Tip: Before debug servo, we must ensure it don't keep running, if motor parameters are wrong, the motor will be burnout, after trial operation OK, then do other operation.

4.1 Motor angle self-learning

On display rdy state, first check motor type, see if it's right. If it's wrong, please set the correct motor type. After setting correct motor type, it will hint power loss restart fault (Er320), after restart, driver will set correct motor parameters by motor type.

(1) Set motor parameters correctly

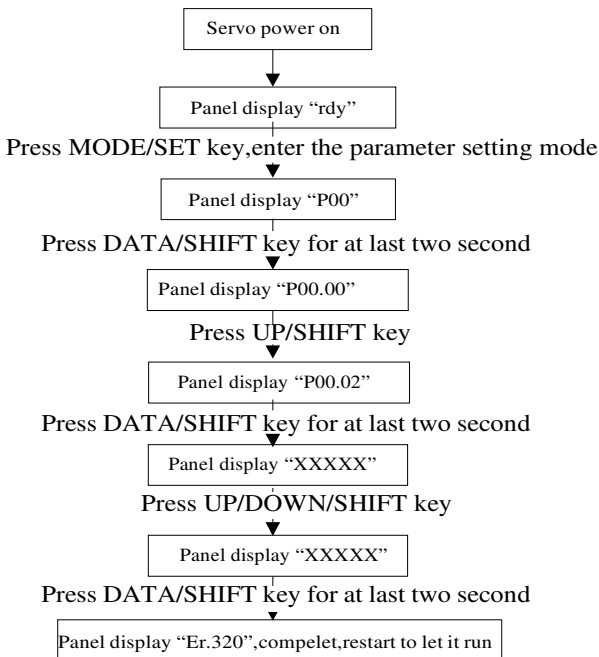

(2) Outage, then power-on, enter parameter P0d-03, hold pressing DATE key, display 0, press up key, hold pressing DATE/SHIFT key, motor turning a little, arise Er.320, learning complete, power off and restart. (if arise Er.320--Phase error alarm, then change V and W of motor's U, V, W)

(3) Power on, trial operation, enter parameter P0d-11, set JOG trial operation speed, hold pressing DATE/SHIFT key, arise -JOG, press UP/DOWN key, if motor is running with setting speed, it's regular, then it can equip on the device.

4.2 Load inertia self-learning

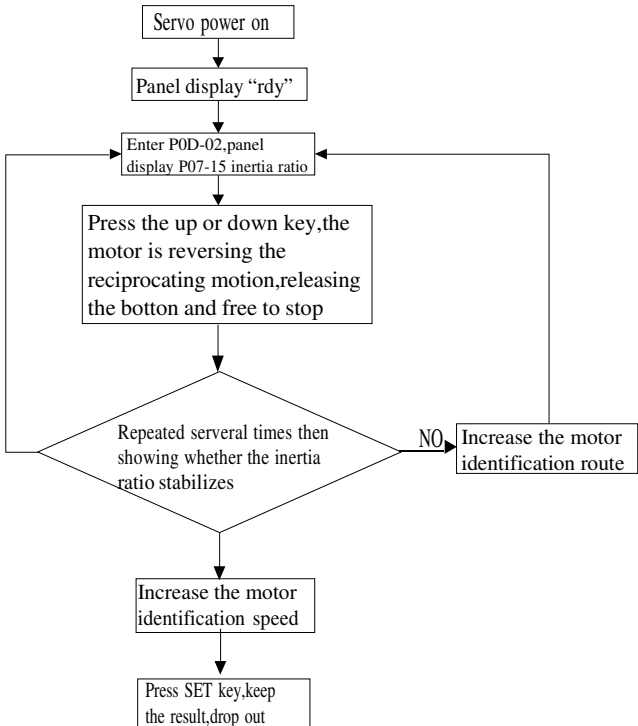

Introduction:

*If on the default condition that P07-15=1, as inertia ratio is too small

that cause the actual speed can't match the command,identify failure.This moment, we shall set a reasonable value to P07-15,preset value shall start at 5 times,gradually increasing to a appropriate value which can make identify successfully.

*Off-line inertia identify model,generaly suggest to use triangle wave mode,if appear some occasion that identification is not good,then we can use step rectangular wave mode.

*When P08-05=1,we shall notice mechanical travel,prevent the accident may be caused by over range during Off-line inertia identification.

Chapter 5 Operation

5.1 Trial operation





5.1.1 Servo motor's trial operation

Make sure the power and the motor's main circuit cable, encoder cable is properly connected. Servo motor in the trial operation state can not smoothly rotate, many reasons are due to wiring errors. So please confirm again. After confirming the wiring is correct, make a trial operation for the servo motor in the order shown below.

Disconnect the servo motor and the mechanical connection part, only the servo motor is in a fixed state. To avoid unexpected accidents, in the present description, making the servo motor in the no-load state (state like coupling with the belt from the servo motor), conduct the servo motor's trial operation.

Joy(JOG)mode operation (P0d-11)

Operation step	The display after operation	Built-in panel operator	Explanation
1		 MODE/SET	Press the MODE / SET key to enter the auxiliary function mode.
2		 ▲ ▼	Press the UP or DOWN key to set P0d-02. *Bits that can operate blink
3		 DATA (MODE/SHIFT) (Over 2 second)	Press the DATA button for 2 second or more, the display appears as shown on the left, enter the JOG running speed setting.
4		 MODE (MODE/SHIFT) (Over 2 second)	Press the DATA / SHIFT key to enter the servo ON (servo motor with power) state, enter JOG mode.

5			Press UP key (forward rotation) or DOWN key (reverse rotation). During the time of pressing the key, the servo motor rotates.
6		 MODE/SET	Press the MODE / SET key to enter the servo OFF (servo motor without power) state, exit JOG mode.

The direction of the servo motor's rotation depends on the "Selection of rotation direction of the" user parameters P01-02'.The factory setting of P01-02 is shown in the example above.

P05-04	Jog(JOG) speed			
	Setting range	Setting unit	Default	Power restart
	0 ~ 3000	1min-1	100	Don't need
The motor rotational speed instruction value of setting accessibility "jog (JOG) mode (P0D-11)",				

In the case of instruction controller that does not issue commands, servo motor can also be run with a digital operation. To perform jog(JOG) mode, you must meet the following conditions.

1. Servo ON (/ S-ON), input signal is OFF (H-level) state.

2. By assigning an external input signal setting, not conduct "effective internal servo ON" setting. In addition, please pay more attention, in joy(JOG) mode operation, the forward rotation drive prohibited (P-OT) and reverse rotation drive prohibited (N-OT) signal is invalid.

5.2 Position control mode selection

Position control mode usually uses number of pluses to ensure displacement of movement, extra input pluse frequency to ensure the magnitude of rotational speed. As position mode can strictly control speed and position, so it usually used for positioning device, it is the control mode which servo apply most, main applications such as mechanical arm, chip moulder, engraving and milling cutting, CNC machine and so on.

5.2.1 Positioning control mode instructions

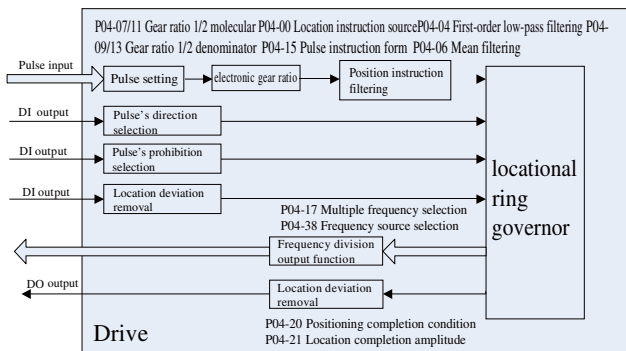

Position mode using steps as follow:

1. Connect servo driver's main circuit line, control circuit line, motor power line, encoder line, brake line (if motor has brake function) properly, after power up, driver's panel display "rdy", it indicates that the connections are correct.
2. Using JOG mode, make sure the motor is running regularly.
3. Connect the line which needed by pluse command, pluse direction and DIDO of CN1 terminal, setting related function code.
4. After servo enable, make sure the connection and motor rotate direction is correct by send low speed pluse command.

5.2.2 User parameters setting

P04-00	Position command source			
	Setting range	Setting unit	Default	Power restart
	0~2	1	0	Don't need

0- Pluse command

1- Step value given

2- Multiple position command given

P04-15	Pluse command form			
	Setting range	Setting unit	Default	Power restart
	0~3	1	0	Need







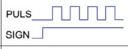
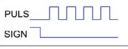

0- Direction+pluse,positive logic

1- Direction+pluse,negative logic

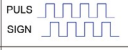
2- A phase + B phase orthogonal pluse, 4 times frequency

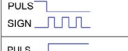
3- CW + CCW

Pluse command form's specific form as following picture:

Pluse command form	Positive Logic		Negative Logic [‡]	
	forward	reversal	forward	reversal [‡]
direction+pluse				
A phase + B phase or orthogonal pluse (A相+B相)				
CW+CCW				
				

P04-07	Numerator of the electronic gear ratio 1			
	Setting range	Setting unit	Default	Power restart
	1~1073741824	1	8388608	Don't need
P04-09	Denominator of the electronic gear ratio 1			
	Setting range	Setting unit	Default	Power restart
	1~1073741824	1	10000	Don't need

P04-11	Numerator of the electronic gear ratio 2			
	Setting range	Setting unit	Default	Power restart
	1~1073741824	1	8388608	Don't need
P04-13	Denominator of the electronic gear ratio 2			
	Setting range	Setting unit	Default	Power restart
	1~1073741824	1	10000	Don't need

Electronic gear ratio's main function is to make position command plus zoom in or zoom out, send processed value as position reference command to position loop for calculation. If connect motor and load by using reduction gear, assume reduction ratio of motor shaft and load machinery side is n/m (motor shaft rotate m circles, load shaft rotate n circles), electronic gear ratio's calculation formula as follows:

$$\text{Electronic gear ratio} = \frac{P04-07}{P04-09} = \frac{\text{Encoder resolution}}{\text{The resolution of the rotation of the load axis}} * \frac{m}{n}$$

At present, driver supports two-way electronic gear ratio, switchover by DI terminal input.

P04-04	Filter time of first-order lowpass			
	Setting range	Setting unit	Default	Power restart
	0.0ms~6553.5ms	0.1ms	0.0ms	Don't need
P04-06	Filter time of positioning command moving average value			
	Setting range	Setting unit	Default	Power restart
	0.0ms~128.0ms	0.1ms	0.0ms	Don't need

Position command filter function is filtering input position command, making servo motor rotate more smoothly, reducing impact to load. At present, we support two modes to position command filter: first-order lowpass filter and average filter, this function has a obvious effect on the following occasions:

<1>Upper device output pulse command has no accelerate/decelerate operation and accelerate/decelerate speed is high;

<2>Command pluse frequency too low;

<3>Electronic gear ratio over 10 times;

Introduction:After filter, there is no effect on amount of pluse position command;

5.3 Speed control mode running

Speed control mode control rotational speed by analog input,function code digital value given or communication given,mainly used for some constant speed occasions,usually used by servo,typical applied occasion such as: analog carves-milling machine,upper computer adopt position control,servo drivers adopt speed control mode.

5.3.1 Speed control mode instructions

Speed mode using steps as follow:

- 1.Connect servo driver's main circuit line,control circuit line,motor power line,encoder line,brake line(if motor has brake function) properly,after power up,driver's panel display "rdy",it indicates that the connections are correct.

- 2.Using JOG mode,make sure the motor is running regularly.

- 3.Connect the line which needed by speed command, speed direction and DI/DO of CN1 terminal,setting related function code.

4. After servo enable,make sure the connection and motor rotate direction is correct by input low-speed speed command.

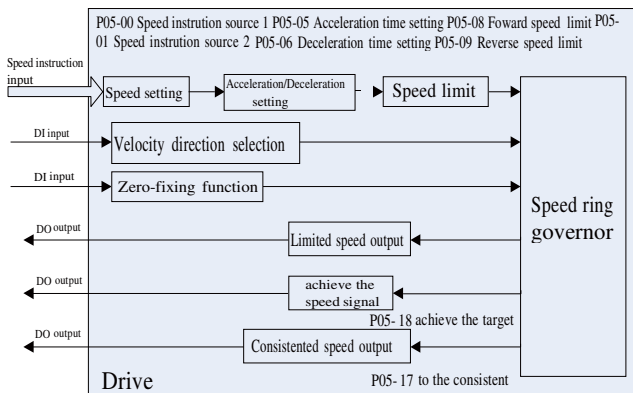

5.3.2 User parameters setting

P05-00	Main speed command A source			
	Setting range	Setting unit	Default	Power restart
	0~5	1	0	Don't need
0- Digital given(P05-03)				
1- AI1				
2- AI2				
3- AI3(Reserved)				
4- JOG speed command				
5- Multiple speed command				
P05-01	Auxiliary speed command B source			
	Setting range	Setting unit	Default	Power restart
	0~5	1	1	Don't need

0- Digital given(P05-03)				
1- AI1				
2- AI2				
3- AI3(Reserved)				
4- JOG speed command				
5- Multiple speed command				
P05-03	Speed command panel setting value			
	Setting range	Setting unit	Default	Power restart
	-9000rpm~9000rpm	1rpm	200rpm	Don't need
P05-04	JOG speed setting value			
	Setting range	Setting unit	Default	Power restart
	0rpm~3000rpm	1rpm	100rpm	Don't need

The driver offers two speed command sources, it can also assign the switchover between two speed sources. If use analog quantity as speed command source, we need to set correlative parameters of AI in group P02.

P05-05	Accelerate time			
	Setting range	Setting unit	Default	Power restart
	0ms~65535ms	1ms	0ms	Don't need
P05-06	Decelerate time			
	Setting range	Setting unit	Default	Power restart
	0ms~65535ms	1ms	0ms	Don't need

The function of accelerate decelerate time is change the speed command which has a great change to the smooth speed command of constant acceleration and deceleration, in other words, its aim is to control acceleration and deceleration by setting accelerate/decelerate time. With speed control mode, if the given speed command has a great change, it will cause the motor arise pulsatile and vibratory phenomenon, if increase the accelerate/decelerate time of soft boot, then it can realize the smooth start of motor, avoid the above situation, damage the mechanical parts.

P05-07	Maximum speed limit value			
	Setting range	Setting unit	Default	Power restart
	0rpm~9000rpm	1rpm	9000rpm	Don't need
P05-08	Forward speed limit value			
	Setting range	Setting unit	Default	Power restart
	0rpm~9000rpm	1rpm	9000rpm	Don't need
P05-09	Reverse speed limit value			
	Setting range	Setting unit	Default	Power restart
	0rpm~9000rpm	1rpm	9000rpm	Don't need

Effective forward speed limit values are P05-07,P05-08,the minimum of motor's maximum speed;Effective reverse speed limit values are P05-07,P05-09,the minimum of motor's maximum speed;

5.3.3 Introduction of analog quantity as speed command input

Issued to the servo unit in the form of analog voltage instruction,places the input voltage proportional to the speed of the servo motor to conduct the speed control.

Kind	Signal name	Connector pins' number	Name
Input	V-REF	CN1-30/43	Speed instruction input
	GND	CN1-44	Speed instruction input using signal ground

Use during the speed control (analog voltage instruction).(P05-00=1,2)

Use P02-80 to set the speed instruction input gain.

■Input specifications

- Input range: DC±0V ~ ±10V/rated speed
- The maximum allowable input voltage: DC±12V

·The setting example

P02-80=3000:the rated speed when the voltage is ± 10V

Specific examples are shown below.

Speed command input	Direction of rotation	Rotate speed	Motor type
+6V	forward	1800min-1	3000min-1
+1V	forward	300min-1	3000min-1
-3V	reverse	-900min-1	3000min-1

■ Examples of input circuit

- In order to be able to take effective measures to prevent interference, be sure to use the multi-stranded wires when wiring。
- Examples of variable resistor

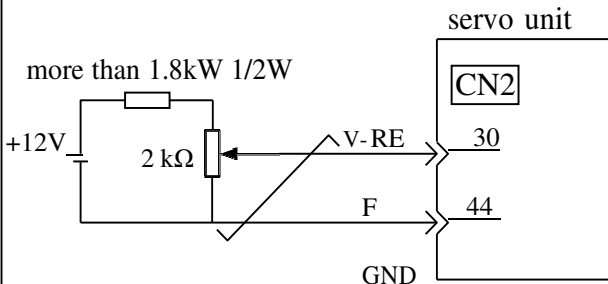

When using the programmable controllers in the instruction controller to conduct the position control, the controller is connected to the instruction controller's speed instruction output terminals.

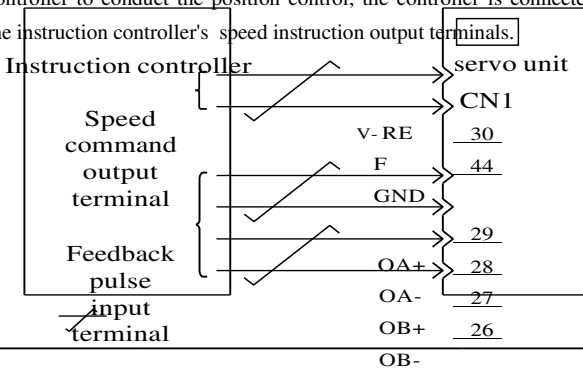

____ Stranded wire

5.4 Torque control mode running

Torque control mode change the torque size by change analog quantity's setting instantaneously or change function code's value with

communication,mainly apply to the devices which have strict requirements on the force of material such as winding and unreeling,typical application's

occasion like winding device or pull fiber equipment which controlled by tension. The setting of torque need changing with winding radius. Make sure the force of material not changing with winding radius.

5.4.1 Torque control mode instructions

Torque mode using steps as follow:

1. Connect servo driver's main circuit line, control circuit line, motor power line, encoder line, brake line (if motor has brake function) properly, after power up, driver's panel display "rdy", it indicates that the connections are correct. 2. Using JOG mode, make sure the motor is running regularly.

3. Connect the line which needed by torque command, torque direction and DIDO of CN1 terminal, setting related function code.

4. After servo enable, set a lower speed limit value, exert a forward or reverse torque command on servo. make sure the motor rotate direction and rotate speed's limitation is correct. If it's normal then we can use it.

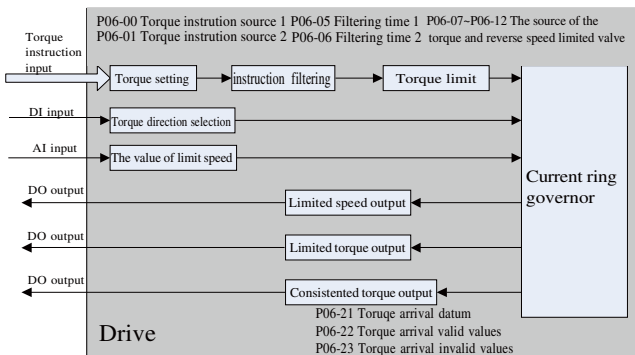

5.4.2 Torque command input

Issued to the servo unit in the form of analog voltage instruction, places the input voltage proportional to the torque of the servo motor to conduct the torque control.

Kind	Signal name	Connector pin number	Name
------	-------------	----------------------	------

Input	T-REF	CN1-43	Torque instruction input
	GND	CN1-44	Torque instruction input using signal ground

Use during the process of torque control (analog voltage instruction)

Use P02-81 to set the torque instruction input gain.

■ Input specifications

- Input Range: $DC\pm 0V \sim \pm 10V$ /the rated torque
- The maximum allowable input voltage: $DC\pm 12V$
- (The factory setting)

P02-81=1.00: Rated torque when

the voltage is $\pm 10V$

+3V input: 30% rated torque when

it is in the positive direction

+9V input: 90% rated torque when

it is in the positive direction

-1V input: 10% rated torque when

it is in the reverse direction

to change the voltage input corresponding rated torque times by the user parameter P02-81.

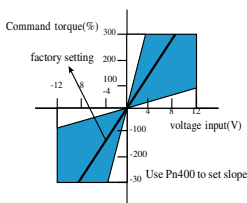

■ Examples of input circuit

To be able to take effective measures to prevent interference, be sure to use the multi-stranded wires when wiring

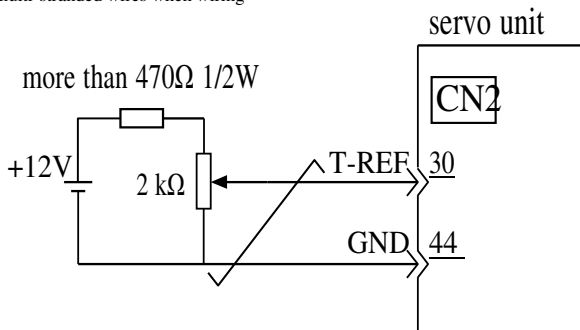

■ The confirmation of internal torque reference

1. Confirmed by internal torque reference panel operator. Can confirm that the internal torque reference in monitor mode (POB-02).
2. Confirmed by monitoring internal analog torque instruction.can

5.4.3 The speed limit when it is torque control

Since when it is torque control, need to control the servo motor to input the issued instruction's torque. so the motor speed's management is not performed. If the mechanical side's load torque setting is too high, will exceed the mechanical's torque, causing the motor speed greatly improved. As the mechanical side's protective measure, with function to limit the servo motor speed control when it is servo motor's torque control.

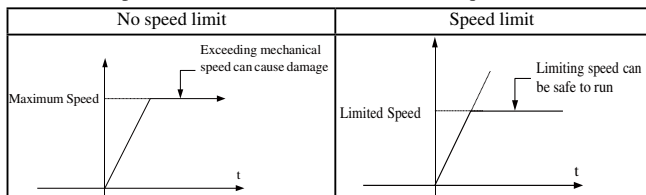

(1) The selection of the speed control mode (torque limiting options)

The user parameter	Contents
P06-17	0-Internal speed limit, set P06-19、P06-20 as forward/reverse speed limit
	1-Analog speed limit, according to P06-18 set AI1, AI2 as speed limit
	2-DI Switch speed limit, through DI input set P06-19 or P06-20 as speed limit

(2) Internal speed limit function

P06-19	The speed limit when it is torque control			
	Setting range	Setting unit	Default	Power restart
	0~9000rpm	1rpm	3000rpm	Don't need

The motor rotate speed limit when set the torque limit.
Even more than the value of the maximum speed of the servo motor set in P06-19, the actual value is still limited to the maximum rotate speed of the servo motor.

monitor by analog, monitoring internal instruction torque by analog voltage instruction .

(3) Output speed limit function

Kind	Signal name	Connector pin number	Name
Input	V-REF	CN1-30/43	Output speed limit input
	GND	CN1-44	Signal ground

P02-80	Speed command input gain			
	Setting range	Setting unit	Default	Power restart
	0~9000rpm	1rpm	3000rpm	Don't need

■The theory of speed limit: Over the range of speed limit, places the speed difference of speed limit proportional to the torque of the servo motor to conduct the negative feedback, then we can back to the range of speed limit. So, actual motor rotate speed limit will change with loading condition.

(4) Output signal of motor rotate speed limit

Kind	Signal name	Connector pin number	Setting	Significance
Output	/V-LT	Need to assign CN1-□□	ON=L level	Are limiting the motor speed
			OFF=H level	Not the motor speed limit state

When conduct the torque limit, if the motor speed reaches the set value P06-19, P06-20 or the speed limit basing on the analog voltage instruction, will output /V-LT signal. must conduct the output terminals assigned by the user parameters P03

5.4.4 Absolute encoder

This section applies to servo driver with absolute encoder and it's invalid for servo driver with incremental encoder.

Multi-turn type absolute encoder can not only detect the position of motor at rotate a circle but also count the circle numbers of motor, single circle resolution is decided by the motor type's encoder (17 bits ~ 23 bits), it can memorize 16 bits' multi-turn data. The absolute system constituted by

using absolute encoder can be divided into absolute position linear mode and absolute position rotate mode,can be used on position,speed and torque control mode,when the driver is power down,encoder can back-up data by battery equipment,after power on,driver can calcute the absolute position of machinery by the absolute position of encoder,it don't need perform the mechanical origin reset operation repeatedly.When EMD100 servo driver match the absolute encoder,we need set corresponding motor type(P1D-00),choose corresponding motor type and set the servo into the absolution position mode(P01-00=7),when we connect the bettery first time,the servo will display Er.220(encoder bettery error),set the servo P0D-20=1 reset the encoder error,then perform the origin reset operation.

This servo driver support Tamawaga 17/23bits absolute single-circle and multi-circle encoder.Multi-circle's data is +32767 ~ -32768.When higher than the upper limit of forward direction(+32767),Multi-circle's data change to -32768.When lower than the lower limit of reserved direction(-32767),Multi-circle's data change to +32768.When standard equipped our company's motor,you only need choose corresponding motor code.

Chapter 6 Parameters list

6.1 User parameters

6.1.1 Main parameters

(NOTE) The detail of property is instead by the following pictures:

☆ : Don't need power restart/With immediate effect;

★ : Need power restart/Power on next time;

● : Read only;

Func. Code	Name	Setting range	Unit	Default	Property
Group 00:Servo driver parameters					
P00-02	Servo driver type	0~65535	-	-	★
Group 01:Basic control parameters					
P01-00	Control mode selection	0.Speed mode 1.Position mode 2.Torque mode 3.Speed mode<->Torque mode 4.Position mode<->Speed mode 5.Position mode<->Torque mode 6.Position mode<->Speed <->Torque mixed mode 7.Absolute position mode	1	1	☆
P01-01	System parameter initialization	0.No function 1.Restore factory settings(except group P0/P1D) 2.Clear error log	1	0	☆
P01-02	Panel warning display selection	0.Display warning information 1.No display warning information	1	0	☆
P01-03	Selection of servo off stop mode	0.Coast to stop ,keep free running state 1.Zero-speed stop ,keep free running state	1	0	☆

Func. Code	Name	Setting range	Unit	Default	Property
P01-04	Stop mode of over range	0. Coast to stop,keep free running state 1. Scram torque stop,position locking state 2. Scram torque stop,keep free running state	1	1	☆
P01-05	Selection of fault which can reset stop mode	0. Coast to stop,keep free running state 1. zero-speed stop,keep free running state	1	0	☆
P01-09	Selection of rotate direction	0. Use CCW direction as forward direction(A lead B) 1. Use CW direction as forward direction(A lag B)	1	0	★
P01-10	Selection of divisible frequency output pulse direction	0. Use CCW direction as forward direction(A lead B) 1. Use CW direction as forward direction(reserve mode,A lag B)	1	0	★
P01-11	Minimum speed set	0.2~14.0rpm	0.1 rpm	4.0 rpm	★
P01-12	Delay time of brake open when servo ON	20ms~500ms	1	250ms	☆
P01-13	Delay time of brake output when zero-speed servo OFF	1ms~500ms	1ms	150ms	☆
P01-14	Output speed limit of brake command	0rpm~3000rpm	1rpm	30rpm	☆
P01-15	Delay time of brake output when free stop	1ms~1000ms	1ms	500ms	☆
P01-18	Filter time of servo ON single	0~64	1ms	0	☆

EMD100 Driver

Func. Code	Name	Setting range	Unit	Default	Property
P01-20	Brake resistor minimum allowed by driver	-	-	40	●
P01-21	Power of built-in brake resistor	-	-	40	●
P01-22	Value of built-in brake resistor	-	-	50	●
P01-23	Heat release coefficient of resistor	10~100	1	30	☆
P01-24	Brake resistor set	0. Use built-in power resistor 1. Use external power resistor and natural cooling 2. Use external power resistor and air cooling 3. Don't use power resistor, absorbed by capacitor	1	0	☆
P01-25	External brake resistor power	1W~65535W	1W	-	☆
P01-26	External brake resistor value	1~1000 User can set by yourself	1	-	☆
P01-29	User password	0~65535	1	0	★
Group 02: Input parameters					
P02-00	DI function default state 1 (HEX)	0~0xFFFF Bit0-correspond to FunIN.1 Bit0-correspond to FunIN.2 Bit0-correspond to FunIN.16	1	0	★

Func. Code	Name	Setting range	Unit	Default	Property
P02-01	DI function default state 2 (HEX)	0~0xFFFF Bit0-correspond to FunIN.17 Bit0-correspond to FunIN.18 Bit0-correspond to FunIN.32	1	0	★
P02-02	DI function default state 3 (HEX)	0~0xFFFF Bit0-correspond to FunIN.33 Bit0-correspond to FunIN.34 Bit0-correspond to FunIN.48	1	0	★
Func. Code	Name	Setting range	Unit	Default	Property
P02-03	DI function default state 4 (HEX)	0~0xFFFF Bit0-correspond to FunIN.49 Bit0-correspond to FunIN.50 Bit0-correspond to FunIN.64	1	0	★
P02-04	Selection of DI1 terminal's functions	0~36	1	14	☆
P02-05	Selection of DI1 terminal's logic	0.Low level valid 1.High level valid 2.Rising edge valid 3.Falling edge valid 4.Both rising edge and falling edge valid	1	0	☆
P02-06	Selection of DI2 terminal's functions	Same as DI1	1	15	☆
P02-07	Selection of DI2 terminal's logic	Same as DI1	1	0	☆
P02-08	Selection of DI3 terminal's functions	Same as DI1	1	13	☆

EMD100 Driver

Func. Code	Name	Setting range	Unit	Default	Property
P02-09	Selection of DI3 terminal's logic	Same as DI1	1	0	☆
P02-10	Selection of DI4 terminal's functions	Same as DI1	1	2	☆
P02-11	Selection of DI4 terminal's logic	Same as DI1	1	0	☆
P02-12	Selection of DI5 terminal's functions	Same as DI1	1	1	☆
P02-13	Selection of DI5 terminal's logic	Same as DI1	1	0	☆
P02-14	Selection of DI6 terminal's functions	Same as DI1	1	12	☆
P02-15	Selection of DI6 terminal's logic	Same as DI1	1	0	☆
P02-16	Selection of DI7 terminal's functions	Same as DI1	1	3	☆
P02-17	Selection of DI7 terminal's logic	Same as DI1	1	0	☆
P02-18	Selection of DI8 terminal's functions	Same as DI1	1	31	☆
P02-19	Selection of DI8 terminal's logic	Same as DI1	1	0	☆
P02-20	Selection of DI9 terminal's functions	Same as DI1	1	0	★
P02-21	Selection of DI9 terminal's logic	Same as DI1	1	0	★
P02-50	AI1 bias	-5000~5000mV	1mV	0	☆
P02-51	AI1 input filter time	0~655.35ms	0.01 ms	200	☆

Func. Code	Name	Setting range	Unit	Default	Property
P02-52	AI1 input median filter enable	0.Forbid 1.Enable	1	1	☆
P02-53	AI1 dead zone	0~1000.0mV	0.1 mV	100	☆
P02-54	AI1 zero drift	-500.0~500.0mV	0.1 mV	0	☆
P02-55	AI2 bias	-5000~5000mV	1mV	0	☆
P02-56	AI2 input filter time	0~655.35ms	0.01 ms	200	☆
P02-57	AI2 input median filter enable	0.Forbid 1.Enable	1	1	☆
P02-58	AI2 dead zone	0~1000.0mV	0.1 mV	100	☆
P02-59	AI2 zero drift	-500.0~500.0mV	0.1 mV	0	☆
P02-80	Analog quantity 100% correspond to speed value	0rpm~9000rpm	1rpm	3000rpm	☆
P02-81	Analog quantity 100% correspond to torque value	1.00~8.00 times rated torque	1.00	1.00 times rated torque	☆
P03-00	Selection of DO1 terminal's functions	0~19	1	1	☆
P03-01	Selection of DO1 terminal's logic level	0-Output low level when effective (optocoupler breakover) 1-Output high level when effective (optocoupler turn-off)	1	0	☆
P03-02	Selection of DO2 terminal's functions	Same as DO1	1	5	☆
P03-03	Selection of DO2 terminal's logic level	Same as DO1	1	0	☆
P03-04	Selection of DO3 terminal's functions	Same as DO1	1	3	☆

EMD100 Driver

Func. Code	Name	Setting range	Unit	Default	Property
P03-05	Selection of DO3 terminal's logic level	Same as DO1	1	0	☆
P03-06	Selection of DO4 terminal's functions	Same as DO1	1	11	☆
P03-07	Selection of DO4 terminal's logic level	Same as DO1	1	0	☆
P03-08	Selection of DO5 terminal's functions	Same as DO1	1	16	☆
P03-09	Selection of DO5 terminal's logic level	Same as DO1	1	0	☆
P03-10	Selection of DO6 terminal's functions	Same as DO1	1	0	☆
P03-11	Selection of DO6 terminal's logic level	Same as DO1	1	0	☆
P03-12	Selection of DO7 terminal's functions	Same as DO1	1	0	☆
P03-13	Selection of DO7 terminal's logic level	Same as DO1	1	0	☆
P03-14	Selection of DO8 terminal's functions	Same as DO1	1	0	☆
P03-15	Selection of DO8 terminal's logic level	Same as DO1	1	0	☆

Func. Code	Name	Setting range	Unit	Default	Property
P03-22	Selection of DO source	Bit0-DO1 source Bit1-DO2 source Bit2-DO3 source Bit3-DO4 source Bit4-DO5 source Bit5-DO6 source Bit6-DO7 source Bit7-DO8 source Bitx=0:DO given by driver Bitx=1:DO given by communication	-	0	☆
*P03-50	Selection of AO1 signal	00-Motor rotate speed(1V/1000rpm) 01-Speed command 02-Torque command (1V/100%) 03-Positional deviation (0.05V/1 command unit) 04-Position amplifier deviation (after electronic gear) (0.05V/1 encoder pluse unit) 05- Position command speed(1V/1000rpm) 06- Positioning complete command (complete:5V not complete :0V) 07- Speed feedforward (1V/1000rpm)	1	0	☆
*P03-51	AO1 offset voltage	0-10000mV	1mV	5000mV	☆
*P03-52	AO1 rate	-99.99~99.99	0.01 times	1.00	☆
*P03-53	Selection of AO2 signal	same as AO1	1	0	☆
*P03-54	AO2 offset voltage	0-10000mV	1mV	5000mV	☆
*P03-55	AO2 rate	-99.99~99.99	0.01 times	1.00	☆

EMD100 Driver

Func. Code	Name	Setting range	Unit	Default	Property
*This feature is reserved					
Group 04:Position control parameters					
P04-00	Source of position command	0-Pulse command 1-Punch advance given 2-Multistage position given	1	0	☆
P04-01	Selection of high/low speed pulse position command	0-Low speed pulse position command 1-High speed pulse position command	1	0	☆
P04-02	Command pulse number of motor rotate a circle	0~8388608	1	0	☆
P04-04	First order low pass filtering time of position command	0.0ms~6553.5ms	0.1ms	0.0ms	☆
P04-05	Punch advance	-9999~9999	1	50	☆
P04-06	Average time of position command move	0.0ms~128.0ms	0.1ms	0.0ms	☆
P04-07	Electronic tooth ratio 1(Numerator)	1~1073741824	1	8388608	☆
P04-09	Electronic tooth ratio 1(Denominator)	1~1073741824	1	10000	☆
P04-11	Electronic tooth ratio 2(Numerator)	1~1073741824	1	8388608	☆
P04-13	Electronic tooth ratio 2(Denominator)	1~1073741824	1	10000	☆
P04-15	Pulse command form	0-Dirction+pulse positive logic 1-Dirction+pulse negative logic 2-A phase+B phase orthogonal pulse,4 times frequency 3-CW+CCW	1	0	★

Func. Code	Name	Setting range	Unit	Default	Property
P04-16	Selection of positional deviation clear action	0-Servo OFF and clear positional deviation pulse when faults occurred 1-Clear positional deviation pulse when faults occurred 2- DI input clear positional deviation pulse when servo off	1	0	☆
P04-17	Frequency division pulse number of encoder	35~32767	1	2500	★
P04-19	Selection of speed feedforward control	0-No speed feedforward 1-interior speed feedforward 2-use AI1 as speed feedforward input 3-use AI2 as speed feedforward input	1	1	☆
P04-20	Output condition of positioning complete signal (COIN)	0- Output when positional deviation absolute value less than positioning complete range 1- Output when positional deviation absolute value less than positioning complete range and position command is 0 after filtering 2- Output when positional deviation absolute value less than positioning complete range and position command is 0	1	0	☆
P04-21	Positioning complete range	1~65535 command unit	1	6000 command unit	☆
P04-22	Positioning complete approach signal range	1~65535 command unit	1	65535 command unit	☆
P04-23	Interrupt fixed length enable	0-Forbid 1-Enable	-	0	★

Func. Code	Name	Setting range	Unit	Default	Property
P04-24	Interrupt fixed length displacement	0~1073741824 (command unit)	1	10000 command unit	☆
P04-26	Interrupt fixed length constantly running speed	1rpm~9000rpm	1rpm	200	☆
P04-27	Interrupt fixed length acceleration/ deceleration time	0~1000	1ms	10ms	☆
P04-29	Fixed length locking relieve signal enable	0-No 1-Yes	1	1	☆
P04-30	Original point reset enable control	0- Close origin reset function 1- Input ORGSET signal through DI to enable origin reset function 2- Input ORGSET signal through DI to enable electrical reset function 3- Immediately start origin reset after power on 4- Immediately process origin reset 5- Start electrical reset command 6- Using current position as origin	1	0	☆

Func. Code	Name	Setting range	Unit	Default	Property
P04-31	Original point reset mode	0-Forward return to zero,deceleration point,original point is original point switch 1-Reverse return to zero,deceleration point,original point is original point switch 2-Forward return to zero,deceleration point,original point is motor Z signal 3-Reverse return to zero,deceleration point,original point is motor Z signal 4-Forward return to zero,deceleration point is original point switch ,original point is motor Z signal 5-Reserve return to zero,deceleration point is original point switch ,original point is motor Z signal 6-Forward return to zero,deceleration point,original point is forward over-range switch 7-Reverse return to zero,deceleration point,original point is reverse over-range switch 8-Forward return to zero,deceleration point is forward over-range switch,original point is motor Z signal 9-Reverse return to zero,deceleration point is reverse over-range switch,original point is motor Z signal	1	0	☆

EMD100 Driver

Func. Code	Name	Setting range	Unit	Default	Property
P04-32	Speed of high speed search original point switch signal	0~3000	1rpm	100rpm	☆
P04-33	Speed of low speed search original point switch signal	0~1000	1rpm	10rpm	☆
P04-34	Acceleration/ deceleration time of limit search original point	0~1000	1ms	1000	☆
P04-35	Time of limit seek original point	0~65535	1ms	10000	☆
P04-36	Mechanical origin offset	-1073741824~1073741824	1	0	☆
P04-38	Selection of servo pulse output source	0- Encoder frequency division output 1- Pulse command synchronization output	1	0	★
P04-39	Electronic gear ratio DI switch enable	0- Switch after position pulse command is 0 continue 10ms 1- Allow DI switch	1	0	☆

Func. Code	Name	Setting range	Unit	Default	Property
P04-40	Original point reset mode	0- P04.36 is coordinate after original point reset ,meet limit,reverse find original point after restart original point reset enable 1- P04.36 is relative offset after original point reset ,meet limit,reverse find original point after restart original point reset enable 2- P04.36 is coordinate after original point reset,meet limit,reverse find zero-point automatically 3- P04.36 is relative offset after original point reset,meet limit,reverse find zero-point automatically	1	0	★
P04-41	Selection of Z pulse output polarity	0~1	1	1	★
P04-46	Absolute position bias(low 32 bit)	-2147483648~2147483648	1	0	☆
P04-48	Absolute position bias(high 32 bit)	-2147483648~2147483648	1	0	☆
Group 05:Speed control parameters					
P05-00	Source of main speed command A	0-Digital given(P0503) 1-AI1 2-AI2 3-Reserved 4-Reserved 5-Multistage speed command	1	0	☆
P05-01	Source of auxiliary speed command B	0-Digital given(P0503) 1-AI1 2-AI2 3-Reserved 4-Reserved 5-Multistage speed command	1	1	☆

Func. Code	Name	Setting range	Unit	Default	Property
P05-02	Selection of speed command	0- Source of main speed command A 1- Source of auxiliary speed command B 2- A+B 3- A/B switch 4- Communication given	1	0	☆
P05-03	Speed command keyboard setting value	-9000rpm~9000rpm	1rpm	200rpm	☆
P05-04	JOG speed setting value	0rpm~3000rpm	1rpm	100rpm	☆
P05-05	Acceleration slope time of speed command	0ms~65535ms	1ms	0ms	☆
P05-06	Deceleration slope time of speed command	0ms~65535ms	1ms	0ms	☆
P05-07	Maximum rotate speed limit value	0rpm~9000rpm	1rpm	9000rpm	☆
P05-08	Speed forward limit	0rpm~9000rpm	1rpm	9000rpm	☆
P05-09	Speed reverse limit	0rpm~9000rpm	1rpm	9000rpm	☆
P05-11	Selection of torque feedforward	0-No torque feedforward 1-Interior torque feedforward	1	1	☆
P05-15	Zero-position fixed rotate speed threshold value	0rpm~6000rpm	1rpm	10rpm	☆
P05-16	Motor rotate signal speed threshold value	0rpm~1000rpm	1rpm	20rpm	☆
P05-17	Width of speed accordance signal	0rpm~100rpm	1rpm	10rpm	☆
P05-18	Speed reach signal threshold value	10rpm~6000rpm	1rpm	1000rpm	☆
P05-19	Zero-speed output signal threshold value	1rpm~6000rpm	1rpm	10rpm	☆
Group 06: Torque control parameters					

Func. Code	Name	Setting range	Unit	Default	Property
P06-00	Source of main torque command A	0-Digital given(P0603) 1-AI1 2-AI2	1	0	☆
P06-01	Source of auxiliary torque command B	0-Digital given(P0603) 1-AI1 2-AI2	1	1	☆
P06-02	Selection of torque command	0- Source of main torque command A 1- Source of auxiliary torque command B 2- A+B source 3-A/B switch 4-Communication given	1	0	☆
P06-03	Torque command keyboard setting value	-300.0%~300.0%	0.1%	0	☆
P06-05	Torque command filter time 1	0.00ms~30.00ms	0.01	0.80ms	☆
P06-06	Torque command filter time 2	0.00ms~30.00ms	0.01	0.80ms	☆
P06-07	Source of torque limit	0-Forward/reverse interior torque limit 1-Forward/reverse external torque limit(using P-CL,N-CL to select) 2- Use T-LMT as external torque limit input 3- Use forward/reverse external torque and external T-LMT's minimum as torque limit(using P-CL,N-CL to select) 4- Use DI to process the switchover of first and second torque	1	0	☆
P06-08	Selection of T-LMT	1- Use AI1 as external torque limit 2- Use AI2 as external torque limit	1	2	☆
P06-09	Forward interior torque limit	0.0%~300.0% (100% corresponds to one times rated torque)	0.1%	300.0%	☆

Func. Code	Name	Setting range	Unit	Default	Property
P06-10	Reverse interior torque limit	0.0%~300.0% (100% corresponds to one times rated torque)	0.1%	300.0%	☆
P06-11	Forward external torque limit	0.0%~300.0% (100% corresponds to one times rated torque)	0.1%	300.0%	☆
P06-12	Reverse external torque limit	0.0%~300.0% (100% corresponds to one times rated torque)	0.1%	300.0%	☆
P06-17	Selection of speed limit source	0- Interior speed limit (P06-19/P06-20) 1- Use V-LMT as external speed limit input 2- Use DI's function 36 to select first or second speed limit input	1	0	☆
P06-18	Selection of V-LMT	1- Use AI1 as external speed limit 2- Use AI2 as external speed limit	1	2	☆
P06-19	Forward speed limit/first speed limit when torque control	0~9000rpm	1rpm	3000rpm	☆
P06-20	Reverse speed limit/second speed limit when torque control	0~9000rpm	1rpm	3000rpm	☆
P06-21	Torque reach base value	0.0%~300.0% (100% corresponds to one times rated torque)	0.1%	0	☆
P06-22	Torque reach effective value	0.0%~300.0% (100% corresponds to one times rated torque)	0.1%	20%	☆
P06-23	Torque reach invalid value	0.0%~300.0% (100% corresponds to one times rated torque)	0.1%	10%	☆
P06-40	Speed over-range window	0.5~30.0ms	0.1ms	1.0ms	☆
Group 07: Gain parameters					
P07-00	Speed loop gain 1	1.0Hz~2000.0Hz	0.1Hz	25.0Hz	☆
P07-01	Speed loop integral time constant 1	0.15ms~512.00ms	0.01 ms	31.83ms	☆

Func. Code	Name	Setting range	Unit	Default	Property
P07-02	Position loop gain 1	0.0Hz~2000.0Hz	0.1Hz	40.0Hz	☆
P07-03	Speed loop gain 2	1.0Hz~2000.0Hz	0.1Hz	40.0Hz	☆
P07-04	Speed loop integral time constant 2	0.15ms~512.00ms	0.01 ms	20.00ms	☆
P07-05	Position loop gain 2	0.0Hz~2000.0Hz	0.1Hz	64.0Hz	☆
P07-08	Setting of second gain mode	0-Use first gain regularly 1-Allow to switch first/second gain,switching condition is P07-09	1	1	☆
P07-09	Selection of gain's switching condition	0-Use first gain regularly 1-Use external DI switch first/second gain 2-Torque command great 3-Speed command great 4-Speed command's changing rate great 5-Speed command high/low speed threshold 6-Position deviation 7-Position command 8-Positioning complete 9-Actual speed great 10-Position command + actual speed	1	0	☆
P07-10	Delay time of gain's switchover	0~1000.0ms	0.1ms	5.0	☆
P07-11	Class of gain's switchover	0~20000	1	50	☆
P07-12	Time lag of gain's switchover	0~20000	1	30	☆
P07-13	Switch time of position gain	0.0~1000.0	0.1	3.0	☆
P07-15	Inertia ratio of load rotate	0.00~120.00	0.01	1	☆
P07-18	Filter time parameter of speed feedforward	0.00ms~64.00ms	0.01 ms	0.50ms	☆
P07-19	Speed feedforward gain	0.0%~100.0%	0.1%	0.0%	☆

EMD100 Driver

Func. Code	Name	Setting range	Unit	Default	Property
P07-20	Filter time parameter of torque feedforward	0.00ms~64.00ms	0.01 ms	0.50ms	☆
P07-21	Torque feedforward gain	0.0%~200.0%	0.1%	0.0%	☆
P07-23	Filter cut-off frequency of speed feedback	100Hz~4000Hz	1Hz	4000Hz	☆
P07-24	PDF control coefficient	0.0%~100.0%	0.1%	100.0%	☆
Group 08:Self-adjusting parameters					
P08-00	Selection of gain self-adjusting mode	0-Manual adjust gain 1-Parameter self-adjusting mode 1,use rigidity class adjust gain parameter 2-Parameter self-adjusting mode 2,enhance speedability	1	0	☆
P08-01	Setting of rigidity class	0~31	1	12	☆
P08-02	Selection of adaptive wave trap mode	0~4	1	0	☆
P08-03	Online inertia recognize mode	0-Close 1- Open,change slowly 2- Open,change generally 3-Open,change quickly	1	0	☆
P08-04	Selection of low frequency resonance suppression mode	0-Manual setup vibrational frequency 1-Automatic setup vibrational frequency	1	0	☆
P08-05	Selection of offline inertia recognize mode	0-Forward/reverse triangular wave mode 1-JOG mode	1	0	☆
P08-06	Maximum speed of inertia recognize	100rpm~1000rpm	1rpm	500rpm	☆
P08-07	Acceleration/ deceleration time of inertia recognize	20ms~800ms	1ms	250ms	☆

Func. Code	Name	Setting range	Unit	Default	Property
P08-08	Waiting time of single inertia recognize complete	50ms~10000ms	1ms	800ms	☆
P08-09	Motor rotate laps of single inertia recognize complete	-	0.01 lap	-	☆
P08-12	First group wave trap frequency	50Hz~4000Hz	1	4000	☆
P08-13	First group wave trap bandwidth class	0~20	1	2	☆
P08-14	First group wave trap depth class	0~99	1	0	☆
P08-15	Second group wave trap frequency	50Hz~4000Hz	1	4000	☆
P08-16	Second group wave trap bandwidth class	0~20	1	2	☆
P08-17	Second group wave trap depth class	0~99	1	0	☆
P08-18	Third group wave trap frequency	50Hz~4000Hz	1	4000	☆
P08-19	Third group wave trap bandwidth class	0~20	1	2	☆
P08-20	Third group wave trap depth class	0~99	1	0	☆
P08-21	Fourth group wave trap frequency	50Hz~4000Hz	1	4000	☆
P08-22	Fourth group wave trap bandwidth class	0~20	1	2	☆
P08-23	Fourth group wave trap depth class	0~99	1	0	☆
P08-24	Result of resonant frequency recognize	-	-	-	☆

EMD100 Driver

Func. Code	Name	Setting range	Unit	Default	Property
P08-30	Disturbance torque compensation gain	0.0%~100.0%	0.1	0.0	☆
P08-31	Filter time of disturbance observer	0.00ms~25.00ms	0.01	0.5	☆
P08-38	Low frequency resonance frequency	1.0~100.0	0.1	100.0	☆
P08-39	Low frequency resonance suppression range	0~10	1	2	☆
Group 09: Fault protection parameters					
P09-00	Input phase loss protection selection	0- Enable fault, forbid warning 1- Enable fault and warning 2- Forbid fault and warning	1	0	☆
P09-03	If execute saving function when power down	0-NO 1-YES	1	0	☆
P09-04	Motor overload protection gain	50%~300%	1%	100%	☆
P09-08	Threshold of over-speed judgement	0~10000	1	0	☆
P09-09	Maximum position pulse frequency	100kHz~4000kHz	1kHz	4000kHz	☆
P09-10	Fault value of too large position deviation	1~1073741824	1	25165824	☆
P09-12	Run away protection enable	0- Without run away protect 1- Open run away protection	1	1	☆
P09-16	Judgement threshold of low frequency resonance position deviation	1~1000	1	5	☆

Func. Code	Name	Setting range	Unit	Default	Property
P09-25	Speed feedback display filter time	0~5000ms	1	50ms	☆
P09-26	Motor overload shield enable	0- Don't shield 1- Shield warning and fault of motor overload	1	0	☆
P09-27	Filter time constant of speed DO	0~5000	1	50ms	☆
P09-32	Locked-rotor overheat protection time window	10~65535	1	200ms	★
P09-33	Locked-rotor overheat protection enable	0~1	1	1	★
Group 0A: Communication parameters					
P0A-00	Servo axis address	1~247, 0 is broadcast address	1	1	☆
P0A-02	Setting of serial port baud rate	0-2400 1-4800 2-9600 3-19200 4-38400 5-57600	1	5	☆
P0A-03	Modbus data format	0-No check, 2 stop bit 1-Even parity check, 1 stop bit 2-Odd Parity check, 1 stop bit 3-No check, 1 stop bit	1	0	☆
P0A-08	Selection of CAN communication rate	0-1M 1-800K 2-500K 3-250K 4-125K 5-100K 6-50K 7-20K	1	2	★
P0A-13	If communication write in function code update to EEPROM	0-Don't update EEPROM 1-Update EEPROM	1	1	☆

Func. Code	Name	Setting range	Unit	Default	Property
P0A-14	Modbus error code	0x0001 illegality function(command code) 0x0002 illegality data address 0x0003 illegality data 0x0004 slave station equipment fault	-	-	●
P0A-25	MODBUS response delay	0~5000ms	1	1	☆
P0A-26	MODBUS 32 bits function code's byte order	0-High 16 bits at front, low 16 bits at back 1-Low 16 bits at front, high 16 bits at back	1	0	☆
Group 0B:Display parameters					
P0B-00	Actual motor rotate speed	-	1rpm	-	●
P0B-01	Target speed	-	1rpm	-	●
P0B-02	Interior torque command (relative to rated torque)	-	0.1%	-	●
P0B-03	Input signal monitor DI	-	-	-	●
P0B-05	Output signal monitor DI	-	-	-	●
P0B-07	Absolute position counter(32 bits)	-	1	-	●
P0B-09	Mechanical angle(pulse start from origin)	-	1p	-	●
P0B-10	Rotate angle (electrical angle)	-	0.1°	-	●
P0B-11	Input position command corresponding given speed	-	1rpm	-	●
P0B-12	Average load rate	-	0.10%	-	●
P0B-13	Position command pulse counter(32 bits)	-	1	-	●
P0B-15	Position deviation counter	-	1p	-	●
P0B-17	Feedback pulse counter(32 bits)	-	1p	-	●

Func. Code	Name	Setting range	Unit	Default	Property
P0B-19	Power on times(32 bits)	-	0.1s	-	●
P0B-21	AI1 sampling voltage value	-	1mv	-	●
P0B-22	AI2 sampling voltage value	-	1mv	-	●
P0B-24	Effective value of phase current	-	0.01A	-	●
P0B-26	Bus voltage	-	0.1V	-	●
P0B-27	Module temperature	-	1°C	-	●
P0B-33	Fault record display	0-Current fault 1-Latest 1 fault 2-Latest 2 faults 9-Latest 9 faults	1	0	☆
P0B-34	Fault code	-	-	-	●
P0B-35	Fault time	-	0.1s	-	●
P0B-37	Motor rotate speed during fault	-	1rpm	-	●
P0B-38	U phase current during fault	-	0.01A	-	●
P0B-39	V phase current during fault	-	0.01A	-	●
P0B-40	Bus voltage during fault	-	0.1V	-	●
P0B-41	DI status during fault	-	-	-	●
P0B-42	DO status during fault	-	-	-	●
P0B-60	Motor absolute position during power on(low 32 bits)	-	1	-	●
P0B-62	Motor absolute position during power on(high 32 bits)	-	1	-	●
Group 0D:Auxiliary control parameters					
P0D-01	Fault reset	0-No operation 1-Fault reset	1	0	☆
P0D-02	Rotational inertia identification	1-Enable	-	-	●

EMD100 Driver

Func. Code	Name	Setting range	Unit	Default	Property
P0D-03	Encoder initial angle identification	0-No operation 1-Identification enable	1	0	☆
P0D-05	Emergency shut down	0-No operation 1-Emergency shut down	1	0	☆
P0D-10	Analog channel zero drift automatic adjustment	0-No operation 1-AI1 adjust 2-AI2 adjust	1	0	☆
P0D-11	JOG function	0-No operation 1-JOG enable	-	-	●
P0D-20	Absolute encoder reset enable	0-No operation 1-Fault reset	1	0	☆
Group 0E: Full closed-loop control parameters					
P0E-01	External encoder usage mode	0-Same as current running direction 1-Different as current running direction	1	0	★
P0E-02	External encoder pulse when motor rotate a lap	0 ~ 1073741824	1 pulse unit	10000	★
P0E-04	Setting of full closed loop position deviation is too large	0 ~ 1073741824	1 pulse unit	10000	☆
P0E-06	Full closed loop control deviation clear setting	0 ~ 100	0rpm	0	☆
P0E-07	Filter time of position deviation	0~6553.5	0.1ms	0	☆
P0E-16	Full closed loop position deviation counter	-1073741824~1073741824	1 pulse unit	0	●
P0E-18	Interior encoder pulse feedback	-1073741824~1073741824	1 pulse unit	0	●
P0E-20	External encoder pulse feedback	-1073741824~1073741824	1 pulse unit	0	●
Group 10: Multistage position control parameters					

Func. Code	Name	Setting range	Unit	Default	Property
P10-00	Multistage position running mode	0- Stop after single run end(P1001 switch segment) 1- Cycle run(P1001 switch segment) 2- DI switch run(DI switch) 3- Order to run(P1001 switch segment,P1005 switch initial segment)	1	1	☆
P10-01	Selection of segment	1~16	1	1	☆
P10-02	Running mode of residual segment	0- Continue running residual segment 1- Start running from first segment	1	0	☆
P10-03	Waiting time unit	0-ms 1-s	1	0	☆
P10-04	Selection of displacement command type	0- Relative displacement command 1- Absolute displacement command	1	0	☆
P10-05	Initial segment selection when cycle running in order	0~16	1	0	☆
P10-12	First displacement	-1073741824~1073741824(command unit)	1	10000 command unit	☆
P10-14	First maximum running speed	1rpm~9000rpm	1rpm	200	☆
P10-15	First acceleration/ deceleration time	0~65535	1ms (1s)	10	☆
P10-16	Waiting time after first segment complete	0~10000	1ms (1s)	10	☆
P10-17	Second displacement	-1073741824~1073741824(command unit)	1	10000 command unit	☆
P10-19	Second maximum running speed	1rpm~9000rpm	1rpm	200	☆
P10-20	Second acceleration/ deceleration time	0~65535	1ms (1s)	10	☆

EMD100 Driver

Func. Code	Name	Setting range	Unit	Default	Property
P10-21	Waiting time after second segment complete	0~10000	1ms (1s)	10	☆
P10-22	Third displacement	-1073741824~1073741824(command unit)	1	10000 command unit	☆
P10-24	Third maximum running speed	1rpm~9000rpm	1rpm	200	☆
P10-25	Third acceleration/ deceleration time	0~65535	1ms (1s)	10	☆
P10-26	Waiting time after third segment complete	0~10000	1ms (1s)	10	☆
P10-27	4th displacement	-1073741824~1073741824(command unit)	1	10000 command unit	☆
P10-29	4th maximum running speed	1rpm~9000rpm	1rpm	200	☆
P10-30	4th acceleration/ deceleration time	0~65535	1ms (1s)	10	☆
P10-31	waiting time after 4th segment complete	0~10000	1ms (1s)	10	☆
P10-32	5th displacement	-1073741824~1073741824(command unit)	1	10000 command unit	☆
P10-34	5th maximum running speed	1rpm~9000rpm	1rpm	200	☆
P10-35	5th acceleration/ deceleration time	0~65535	1ms (1s)	10	☆
P10-36	Waiting time after 5th segment complete	0~10000	1ms (1s)	10	☆
P10-37	6th displacement	-1073741824~1073741824(command unit)	1	10000 command unit	☆
P10-39	6th maximum running speed	1rpm~9000rpm	1rpm	200	☆
P10-40	6th acceleration/ deceleration time	0~65535	1ms (1s)	10	☆

Func. Code	Name	Setting range	Unit	Default	Property
P10-41	Waiting time after 6th segment complete	0~10000	1ms (1s)	10	☆
P10-42	7th displacement	-1073741824~1073741824(command unit)	1	10000 command unit	☆
P10-44	7th maximum running speed	1rpm~9000rpm	1rpm	200	☆
P10-45	7th acceleration/ deceleration time	0~65535	1ms (1s)	10	☆
P10-46	Waiting time after 7th segment complete	0~10000	1ms (1s)	10	☆
P10-47	8th displacement	-1073741824~1073741824(command unit)	1	10000 command unit	☆
P10-49	8th maximum running speed	1rpm~9000rpm	1rpm	200	☆
P10-50	8th acceleration/ deceleration time	0~65535	1ms (1s)	10	☆
P10-51	Waiting time after 8th segment complete	0~10000	1ms (1s)	10	☆
P10-52	9th displacement	-1073741824~1073741824(command unit)	1	10000 command unit	☆
P10-54	9th maximum running speed	1rpm~9000rpm	1rpm	200	☆
P10-55	9th acceleration/ deceleration time	0~65535	1ms (1s)	10	☆
P10-56	Waiting time after 9th segment complete	0~10000	1ms (1s)	10	☆
P10-57	10th displacement	-1073741824~1073741824(command unit)	1	10000 command unit	☆
P10-59	10th maximum running speed	1rpm~9000rpm	1rpm	200	☆
P10-60	10th acceleration/ deceleration time	0~65535	1ms (1s)	10	☆
P10-61	Waiting time after 10th segment complete	0~10000	1ms (1s)	10	☆

Func. Code	Name	Setting range	Unit	Default	Property
P10-62	11th displacement	-1073741824~1073741824(command unit)	1	10000 command unit	☆
P10-64	11th maximum running speed	1rpm~9000rpm	1rpm	200	☆
P10-65	11th acceleration/ deceleration time	0~65535	1ms (1s)	10	☆
P10-66	Waiting time after 11th segment complete	0~10000	1ms (1s)	10	☆
P10-67	12th displacement	-1073741824~1073741824(command unit)	1	10000 command unit	☆
P10-69	12th maximum running speed	1rpm~9000rpm	1rpm	200	☆
P10-70	12th acceleration/ deceleration time	0~65535	1ms (1s)	10	☆
P10-71	Waiting time after 12th segment complete	0~10000	1ms (1s)	10	☆
P10-72	13th displacement	-1073741824~1073741824(command unit)	1	10000 command unit	☆
P10-74	13th maximum running speed	1rpm~9000rpm	1rpm	200	☆
P10-75	13th acceleration/ deceleration time	0~65535	1ms (1s)	10	☆
P10-76	Waiting time after 13th segment complete	0~10000	1ms (1s)	10	☆
P10-77	14th displacement	-1073741824~1073741824(command unit)	1	10000 command unit	☆
P10-79	14th maximum running speed	1rpm~9000rpm	1rpm	200	☆
P10-80	14th acceleration/ deceleration time	0~65535	1ms (1s)	10	☆
P10-81	Waiting time after 14th segment complete	0~10000	1ms (1s)	10	☆
P10-82	15th displacement	-1073741824~1073741824(command unit)	1	10000 command unit	☆

Func. Code	Name	Setting range	Unit	Default	Property
P10-84	15th maximum running speed	1rpm~9000rpm	1rpm	200	☆
P10-85	15th acceleration/ deceleration time	0~65535	1ms (1s)	10	☆
P10-86	Waiting time after 15th segment complete	0~10000	1ms (1s)	10	☆
P10-87	16th displacement	-1073741824~1073741824(command unit)	1	10000 command unit	☆
P10-89	16th maximum running speed	1rpm~9000rpm	1rpm	200	☆
P10-90	16th acceleration/ deceleration time	0~65535	1ms (1s)	10	☆
P10-91	Waiting time after 16th segment complete	0~10000	1ms (1s)	10	☆
Group 11:Multistage speed control parameters					
P11-00	Multistage speed command running mode	0- Stop after single run end(P1101 switch segment) 1- Cycle run(P1101 switch segment) 2- Use external DI switch	1	1	☆
P11-01	Selection of speed command segment	1~16	1	16	☆
P11-02	Selection of running time unit	0-sec 1-min	1	0	☆
P11-03	Acceleration time 1	0ms~65535ms	1ms	10ms	☆
P11-04	Deceleration time 1	0ms~65535ms	1ms	10ms	☆
P11-05	Acceleration time 2	0ms~65535ms	1ms	50ms	☆
P11-06	Deceleration time 2	0ms~65535ms	1ms	50ms	☆
P11-07	Acceleration time 3	0ms~65535ms	1ms	100ms	☆
P11-08	Deceleration time 3	0ms~65535ms	1ms	100ms	☆
P11-09	Acceleration time 4	0ms~65535ms	1ms	150ms	☆

Func. Code	Name	Setting range	Unit	Default	Property
P11-10	Deceleration time 4	0ms~65535ms	1ms	150ms	☆
P11-20	First running speed	-9000~+9000rpm	1rpm	0rpm	☆
P11-21	First running time	0~6553.5	0.1s (m)	5.0s(m)	☆
P11-22	First acceleration/ deceleration time	0-Zero acceleration/ deceleration time 1-Acceleration/ deceleration time 1 2-Acceleration/ deceleration time 2 3-Acceleration/ deceleration time 3 4-Acceleration/ deceleration time 4	1	0	☆
P11-23	Second running speed	-9000~+9000rpm	1rpm	100rpm	☆
P11-24	Second running time	0~6553.5	0.1s (m)	5.0s (m)	☆
P11-25	Second acceleration/ deceleration time	Same as P11-22	1	0	☆
P11-26	Third running speed	-9000~+9000rpm	1rpm	300rpm	☆
P11-27	Third running time	0~6553.5	0.1s (m)	5.0s (m)	☆
P11-28	Third acceleration/ deceleration time	Same as P11-22	1	0	☆
P11-29	4th running speed	-9000~+9000rpm	1rpm	500rpm	☆
P11-30	4th running time	0~6553.5	0.1s (m)	5.0s (m)	☆
P11-31	4th acceleration/ deceleration time	Same as P11-22	1	0	☆
P11-32	5th running speed	-9000~+9000rpm	1rpm	700rpm	☆
P11-33	5th running time	0~6553.5	0.1s (m)	5.0s (m)	☆
P11-34	5th acceleration/ deceleration time	Same as P11-22	1	0	☆
P11-35	6th running speed	-9000~+9000rpm	1rpm	900rpm	☆
P11-36	6th running time	0~6553.5	0.1s (m)	5.0s (m)	☆

Func. Code	Name	Setting range	Unit	Default	Property
P11-37	6th acceleration/ deceleration time	Same as P11-22	1	0	☆
P11-38	7th running speed	-9000~+9000rpm	1rpm	600rpm	☆
P11-39	7th running time	0~6553.5	0.1s (m)	5.0s (m)	☆
P11-40	7th acceleration/ deceleration time	Same as P11-22	1	0	☆
P11-41	8th running speed	-9000~+9000rpm	1rpm	300rpm	☆
P11-42	8th running time	0~6553.5	0.1s (m)	5.0s (m)	☆
P11-43	8th acceleration/ deceleration time	Same as P11-22	1	0	☆
P11-44	9th running speed	-9000~+9000rpm	1rpm	100rpm	☆
P11-45	9th running time	0~6553.5	0.1s (m)	5.0s (m)	☆
P11-46	9th acceleration/ deceleration time	Same as P11-22	1	0	☆
P11-47	10th running speed	-9000~+9000rpm	1rpm	-100rpm	☆
P11-48	10th running time	0~6553.5	0.1s (m)	5.0s (m)	☆
P11-49	10th acceleration/ deceleration time	Same as P11-22	1	0	☆
P11-50	11th running speed	-9000~+9000rpm	1rpm	-300rpm	☆
P11-51	11th running time	0~6553.5	0.1s (m)	5.0s (m)	☆
P11-52	11th acceleration/ deceleration time	Same as P11-22	1	0	☆
P11-53	12th running speed	-9000~+9000rpm	1rpm	-500rpm	☆
P11-54	12th running time	0~6553.5	0.1s (m)	5.0s (m)	☆
P11-55	12th acceleration/ deceleration time	Same as P11-22	1	0	☆
P11-56	13th running speed	-9000~+9000rpm	1rpm	-700rpm	☆
P11-57	13th running time	0~6553.5	0.1s (m)	5.0s (m)	☆
P11-58	13th acceleration/ deceleration time	Same as P11-22	1	0	☆
P11-59	14th running speed	-9000~+9000rpm	1rpm	-900rpm	☆

EMD100 Driver

Func. Code	Name	Setting range	Unit	Default	Property
P11-60	14th running time	0~6553.5	0.1s (m)	5.0s (m)	☆
P11-61	14th acceleration/ deceleration time	Same as P11-22	1	0	☆
P11-62	15th running speed	-9000~+9000rpm	1rpm	-600rpm	☆
P11-63	15th running time	0~6553.5	0.1s (m)	5.0s (m)	☆
P11-64	15th acceleration/ deceleration time	Same as P11-22	1	0	☆
P11-65	16th running speed	-9000~+9000rpm	1rpm	-300rpm	☆
P11-66	16th running time	0~6553.5	0.1s (m)	5.0s (m)	☆
P11-67	16th acceleration/ deceleration time	Same as P11-22	1	0	☆
Group 1D:Motor parameters					
P1D-00	Motor code	0~65535	-	-	★

Explanation:DI terminal's functions as following form:

Setting value of function code	Function 's description
0	No function
1	S-ON: Servo enable
2	ALM-SET: Fault and warning reset
3	GAIN-SEL: Gain switchover
4	CMD-SEL: Switchover of main and auxiliary command
5	DIR-SEL: Selection of multistage speed command's direction
6	CMD1: Switchover 1 of multistage running command
7	CMD2: Switchover 2 of multistage running command
8	CMD3: Switchover 3 of multistage running command
9	CMD4: Switchover 4 of multistage running command
10	M1-SEL: Mode switchover 1
11	M2-SEL: Mode switchover 2
12	ZCLAMP: Zero-position fixation enable
13	INHIBIT: Position command forbid
14	P-OT: Forward over-range switch
15	N-OT: Reverse over-range switch
16	P-CL: Positive external torque control
17	N-CL: Negative external torque control
18	JOGCMD+: Forward JOG
19	JOGCMD-: Reverse JOG
20	PosStep: Punch advance enable
21	HX1: Hand wheel multiplying power signal 1
22	HX2: Hand wheel multiplying power signal 2
23	HX_EN: Hand wheel enable signal
24	GEAR_SEL: Selection of electronic gear ratio
25	ToqDirSel: Setting of torque command's direction
26	SpdDirSel: Setting of speed command's direction
27	PosDirSel: Setting of position command's direction
28	PosInSen: Multistage position enable
29	XintFree: Interrupt fixed length status relieve
30	Nothing
31	HomeSwitch: Original point's switch
32	HomingStart: Original point reset enable

33	XintInhibit: Interrupt fixed length forbid
34	EmergencyStop: Emergency shut down
35	ClrPosErr: Clear positional deviation
36	V_LmtSel: Source of interior speed limit

Explanation:DO terminal's functions as following form:

Setting value of function code	Function 's description
0	Nothing
1	S-RDY: Servo get ready
2	TGON: Motor rotation
3	ZERO: Zero-speed signal
4	V-CMP: Speed accordance
5	COIN: Positioning complete
6	NEAR: Positioning approach
7	C-LT: Torque limit
8	V-LT: Speed limit
9	BK: Brake
10	WARN: Warning
11	ALM: Fault
12	Nothing
13	Nothing
14	Nothing
15	Xintcoin: Interrupt fixed length complete
16	HomeAttain: Original point return to zero complete
17	ElecHomeAttain: Electric return to zero complete
18	ToqReach: Torque reach
19	V-Arr: Speed reach

Chapter 7 Communication Protocol

7.1 Selection of MODBUS parametes

MODBUS communication mainly set slave station address,communication rate and data format,respectively relative to function code parameters:P0A-00,P0A-02,P0A-03,see chapter 6.1 for details.

7.2 MODBUS protocol

read parameter protocol:

ID+0x03+ADDR(H)+ADDR(L)+0x00+0x01+CRC(L)+CRC(H)

return value;

ID+0x03+0x02+DATA(H)+DATA(L)+CRC(L)+CRC(H)

write parameter protocol:

ID+0x06+ADDR(H)+ADDR(L)+DATA(H)+DATA(L)+CRC(L)+CRC(H)

return value:

ID+0x06+ADDR(H)+ADDR(L)+DATA(H)+DATA(L)+CRC(L)+CRC(H)

write parameter protocol(32 bits):

ID+0x10+ADDR(H)+ADDR(L)+WORD(H)+WORD(L)+BYTE+DATA(H)+DATA(L)+...+CRC(L)+CRC(H)

return value(32 bits):

ID+0x10+ADDR(H)+ADDR(L)+WORD(H)+WORD(L)+CRC(L)+CRC(H)

return data of error command:

ID+(command+0x80)+error code+CRC(L)+CRC(H)

error code	
1	invalid command code
2	invalid function code address
3	invalid data
4	slave station error

example:upper computer send:0x01+0x03+0xff+0xff+0x00+0x01+0x84+0x2E

servo return value:0x01+0x83+0x02+0xC0+0xF1

express data function code address send by upper computer is invalid

7.3 MODBUS applied example

The ID of servo driver which in the following examples is 1.

A. read P04-00 parameter, the value of P04-00 is 0.

upper computer send command:

0x01+0x03+0x04+0x00+0x00+0x02+0xC5+0x3B

servo return value:

0x01+0x03+0x02+0x00+0x00+0xC5+0x3B

B. write P04-00 parameter, set value of P04-00 2.

upper computer send command:

0x01+0x06+0x04+0x00+0x00+0x01+0xB8+0x44

servo return value:

0x01+0x06+0x04+0x00+0x00+0x01+0x09+0x70

Chapter 8 Maintenance and Inspection

8.1 Abnormality diagnosis and treatment measures

8.1.1 Alarm display list

The relationship between the alarm display and the alarm code output ON / OFF is shown in Table 7.1. When alarm occurs, the motor's stopping methods includes the following two.

- DB Stop: Emergency stop method using dynamic brake to stop the motor

- Coast to stop: not have to brake, the natural stopping method due to the motor rotation's frictional resistance.

Table 7.1 The alarm display and output list

Alarm display	Alarm name	Alarm content	May the alarm reset?	Servo alarm(ALM) output
Er.001	Parameters error	Servo unit EEPROM data error	No	H
Er.004	FPGA running error	FPGA's clock,interrupt,calculation error	No	H
Er.005	Parameter setting error	Exceed the setting range of the user parameter value	No	H
Er.010	Matching error	Encoder,servo motor and the capacity of servo unit do not match	No	H
Er.011	Function code parameter save error	Write/read operation of EEPROM error	No	H
Er.012	Function code over-range	Function code parameters of factory unreasonable setting	No	H
Er.020	Software overcurrent	Driver's output current is too large	No	H
Er.021	Hardware overcurrent	IGBT's output current is too large	No	H
Er.022	Driver's output short-circuit to ground	Driver's output wire or motor power wire short-circuit to ground	No	H

Alarm display	Alarm name	Alarm content	May the alarm reset?	Servo alarm(ALM) output
Er.023	UVW phase sequence error	UVW three-phase wiring error,change any two phase	No	H
Er.024	Speed loss fault	Motor occur galloping,speed is out of control	No	H
Er.030	Control voltage error	Control power bus undervoltage	No	H
Er.040	Encoder fault	Encoder signal Z,absolute encoder communication error	No	H
Er.050	AI input voltage is too large	AI input voltage is too large and over 11.5V	No	H
Er.061	Encoder break line error	Encoder not match or communication line is break	No	H
Er.062	Incremental encoder signal Z loss	Signal Z is not captured	No	H
Er.100	DI function repeat distribution	Group P2 function code unreasonable setting	Yes	H
Er.101	DO function repeat distribution	Group P3 function code unreasonable setting	Yes	H
Er.111	Bus overvoltage	The main circuit DC voltage is abnormally high	Yes	H
Er.112	Bus undervoltage	The main circuit DC voltage is abnormally low	Yes	H
Er.113	Overspeed	The number of revolutions of the servo motor is abnormally high	Yes	H
Er.116	Angle self-learning fault	Initial angle identification failure	Yes	H
Er.200	Servo running enable fault	Angle self-learning,off-line inertia identification can't running	Yes	H
Er.201	STO enable	STO signal is valid	Yes	H
Er.210	Input phase loss fault	One phase of three phase main circuit's power is not connected	Yes	H
Er.211	Driver overload	Use torque which over rated value to run continuously	Yes	H
Er.212	Frequency dividing output over-speed	Frequency dividing output speed is too large	Yes	H

Alarm display	Alarm name	Alarm content	May the alarm reset?	Servo alarm(ALM) output
Er.213	Motor overload fault	Use current which over rated value to run continuously	Yes	H
Er.214	Motor locked-rotor	Motor shaft is stuck or load is too large can't rotate	Yes	H
Er.215	Cooling fin overheat	Cooling fin of servo unit overheat	Yes	H
Er.220	Encoder battery fault	Absolute encoder battery fault	Yes	H
Er.221	Encoder count error	Absolute encoder count error	Yes	H
Er.222	Encoder multi-circle count overflow	Absolute encoder multi-circle count overflow	Yes	H
Er.230	Electronic gear ratio set error	Parameters of electronic gear ratio unreasonable setting,0.001~4000	Yes	H
Er.250	Position deviation is too large	Offset pulse exceed the setting value of user parameter	Yes	H
Er.251	Position pulse input is too large	Pulse frequency exceed maximum value setted by user	Yes	H
Er.252	Full closed-loop position deviation is too large	Offset pulse exceed the setting value of user parameter	Yes	H
Er.300	Frequency dividing output setting fault	Pulse dividing setting exceed motor encoder line number	Yes	H
Er.301	Origin point back to zero overtime fault	No valid limit switch signal or searching time is too long	Yes	H
Er.302	AI zero offset too large fault	AI wiring error or zero drift exceed 50mV because of interference	Yes	H
Er.303	Emergency shut down warning	Detected DI emergency shut signal valid	Yes	H
Er.310	Regeneration overload warning	Brake resistance bad contact,rotate speed is too high or load is too large cause brake resistance overload	Yes	H

Alarm display	Alarm name	Alarm content	May the alarm reset?	Servo alarm(ALM) output
Er.312	External brake resistance is too small	External brake resistance less than value asked by driver	Yes	H
Er.313	Motor power line break	Motor power line don't connect good or it has broken	Yes	H
Er.315	Motor overload warning	Load is too large or frequent acceleration/deceleration cause motor overload	Yes	H
Er.320	Power restart	Modify the function code parameter which need power restart	Yes	H
Er.322	Motor forward over-range	Detected forward over-range DI signal vaild	Yes	H
Er.323	Motor reverse over-range	Detected reverse over-range DI signal vaild	Yes	H
Er.324	Input phase loss warning	One phase of three phase main circuit's power is not connected	Yes	H

8.1.2 The causes and treatment measures for the alarm display

If the servo drive has bad situation, then there will be an alarm on the operator panel display Er.XXX. Alarm display and treatment measures are as follows. After processing, if you still do not solve the bad situation, please contact our service department. Table 7.2 is a list of alarm display.

Table 8.2 Causes and treatment measures to the alarm display

Alarm	Alarm contents	Causes and treatment measures
Er.001	Parameters error	Set P01-01=1, restore factory settings
Er.004	FPGA running error	FPGA internal error, if restart can't solve, please contact manufacturer
Er.005	Parameter setting error	Set P01-01=1, restore factory settings
Er.010	Matching error	Inspect if motor, driver type is correct, contact manufacturer;

Alarm	Alarm contents	Causes and treatment measures
Er.011	Function code parameter save error	EEPROM error,contact manufacturer;
Er.012	Function code over-range	Function code parameters of factory unreasonable setting.
Er.020	Software overcurrent	Driver's output current greater than flow point setted
Er.021	Hardware overcurrent	Brake resistance is too small,pulse command is too fast,output short circuit and so on
Er.022	Driver's output short-circuit to ground	UVW wiring short-circuit to ground,wiring again or change cable;Motor short-circuit to ground, please change motor.
Er.023	UVW phase sequence error	UVW three-phase wiring error,change any two phase
Er.024	Speed loss fault	Load drag,UVW phase error,encoder cable loose and so on.
Er.030	Control voltage error	Control power unstable or bad contact;
Er.040	Encoder fault	Encoder signal interference,absolute encoder bad contact or wiring error
Er.050	AI input voltage is too large	AI input voltage is too high or interference is serious.
Er.061	Encoder break line error	Encoder don't match driver or communication wire is break
Er.062	Incremental encoder signal Z loss	Encoder wire bad contact,wiring error or encoder is damaged
Er.100	DI function repeat distribution	Set DI function parameters in group P2 correctly,restore factory settings
Er.101	DO function repeat distribution	Set DO function parameters in group P3 correctly,restore factory settings
Er.111	Bus overvoltage	Input voltage is too high;Brake resistance is too small or loss efficacy;Motor decelerate time is too little;Sampling circuit fault;
Er.112	Bus undervoltage	Input voltage is too low or instantaneous power down

Alarm	Alarm contents	Causes and treatment measures
Er.113	Overspeed	UVW phase error,P09-08 parameter unreasonable setting;input command too fast;
Er.116	Angle self-learning fault	Initial angle identification failure
Er.200	Servo running enable fault	Set DI servo enable signal invalid
Er.201	STO enable	STO signal is valid
Er.210	Input phase loss fault	Input voltage is too low or wiring bad
Er.211	Driver overload	Use torque which over rated value to run continuously,accumulation of heat is too large.
Er.212	Frequency dividing output over-speed	Decrease pulse frequency dividing number P04-17;decrease input pulse frequency
Er.213	Motor overload fault	Driver/motor type error;Frequent acceleration and deceleration can increase acceleration and deceleration time;load is too large;
Er.214	Motor locked-rotor	Motor shaft is stuck or load is too large that can't rotate;UVW wiring error or output break line;encoder break line;
Er.215	Cooling fin overheat	Lowering ambient temperature;Check if fan is working;Check if driver's air intake and air outlet is well-ventilated;
Er.220	Encoder battery fault	Encoder battery is not connected or voltage is too low.
Er.221	Encoder count error	Absolute encoder count error
Er.222	Encoder multi-circle count overflow	Absolute encoder multi-circle count overflow
Er.230	Electronic gear ratio set error	Parameters of electronic gear ratio unreasonable setting,please reset to 0.001~4000.
Er.250	Position deviation is too large	Motor locked-rotor;Input pulse frequency is too high;Setting deviation threshold P09-10 is too small;UVW output break line or loss phase;Encoder break line;
Er.251	Position pulse input is too large	Pulse frequency exceed maximum value P09-09 setted by user

Alarm	Alarm contents	Causes and treatment measures
Er.252	Full closed-loop position deviation is too large	Motor locked-rotor;Input pulse frequency is too high;Setting deviation threshold P0E-08 is too small;UVW output break line or loss phase;Encoder break line;
Er.300	Frequency dividing output setting fault	Pulse dividing setting exceed motor encoder line number,resetP04-17
Er.301	Origin point back to zero overtime fault	No valid limit switch signal or searching time too long,please confirm DI input is valid;Searching time is too long,please increase P04-35 original point searching time.
Er.302	AI zero offset too large fault	AI wiring error or zero drift exceed 50mV because of interference
Er.303	Emergency shut down warning	Detected DI emergency shut signal valid
Er.310	Regeneration overload warning	Brake resistance has a bad contact or a external brake resistance which is larger; Deceleration time is too short when rotate speed is too high;Load is too large.
Er.312	External brake resistance is too small	Change to bigger brake resistance and set P01-27 correctly.
Er.313	Motor power line break	Motor power line don't connect good or it has broken
Er.315	Motor overload warning	Driver/motor type error;Frequent acceleration and deceleration can increase acceleration and deceleration time;load is too large;
Er.320	Power restart	Modify the function code parameter which need power restart
Er.322	Motor forward over-range	Detected forward over-range DI signal vaild
Er.323	Motor reverse over-range	Detected reverse over-range DI signal vaild
Er.324	Input phase loss warning	One phase of three phase main circuit's power is not connected;If use bus joint method,please set P09-00=2.

Chapter 9 Motor Adaptation Table

Motor model	Rated power(kW)	Rated line voltage(V)	Rated line Current(A)	Rated speed(rpm)	Rated torque(N·M)	Max rated torque(N·M)	Rotor inertia(Kg·M ²)
EMM-60KP20A30 □□ YYB	0.2	220	1.3	3000	0.64	1.91	0.0264×10 ⁻³
EMM-60KP40A30 □□ YYB	0.4	220	2.6	3000	1.3	3.8	0.028×10 ⁻³

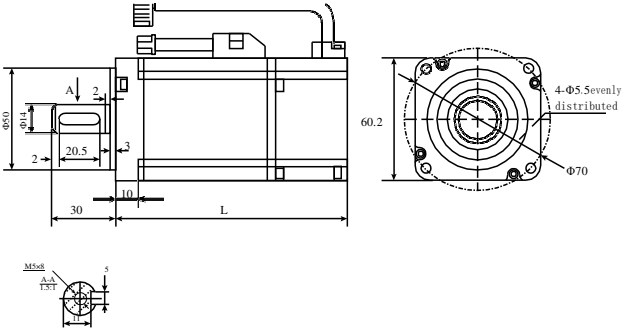

Model	EMM-60KP20A30	EMM-60KP40A30
Without Brake sizeL(mm)	109	108

Motor model	Rated power(kW)	Rated line voltage(V)	Rated line Current(A)	Rated speed(rpm)	Rated torque(N·M)	Max rated torque(N·M)	Rotor inertia(Kg·M ²)
EMM-80KP40A30□□YYB	0.4	220	2.0	3000	1.27	3.8	1.05×10 ⁻⁴
EMM-80KP75A30□□YYB	0.75	220	4.4	3000	2.39	7.16	0.9×10 ⁻⁴
EMM-80KP73A20□□YYB	0.73	220	3.0	2000	3.50	10.5	2.63×10 ⁻⁴
EMM-80KP100A25□□YYB	1	220	4.4	2500	4.00	12	2.97×10 ⁻⁴

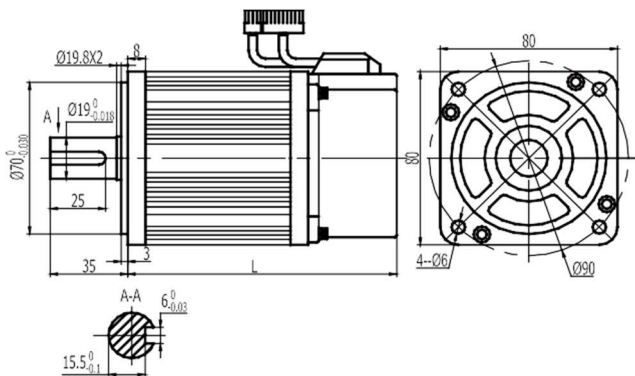

Model	US-80KP40A30	US-80KP73A20	US-80KP75A30	US-80KP100A25
Without Brake size L(mm)	124	119	122.5	191

EMD100 Driver Handbook

Motor model	Rated power(kW)	Rated line voltage(V)	Rated line Current(A)	Rated speed(rpm)	Rated torque(N·M)	Max rated torque(N·M)	Rotor inertia(Kg·M ²)
EMM-130SP100A25□YYB	1.0	220	4.0	2500	4.0	12	0.85×10^{-3}
EMM-130SP100A20□YYB	1.0	220	5.0	2000	5.0	15	1.06×10^{-3}
EMM-130SP150A15□YYB	1.5	220	6.0	1500	10.0	25	1.94×10^{-3}
EMM-130SP150A20□YYB	1.5	220	7.5	2000	7.7	22	1.53×10^{-3}
EMM-130SP150A25□YYB	1.5	220	6.0	2500	6.0	18	1.26×10^{-3}
EMM-130SP200A20□YYB	2.0	220	10.0	2000	10.0	25	1.94×10^{-3}
EMM-130SP200A25□YYB	2.0	220	7.5	2500	7.7	22	1.53×10^{-3}
EMM-130SP200A20□YYD	2.0	380	6.0	2000	10.0	30	2.77×10^{-3}
EMM-130SP200A25□YYD	2.0	380	6.0	2500	7.7	25	1.94×10^{-3}
EMM-130SP230A15□YYD	2.3	380	5.0	1500	15	30	2.77×10^{-3}
EMM-130SP260A25□YYD	2.6	380	6.0	2500	10	25	1.94×10^{-3}
EMM-130SP380A25□YYD	3.8	380	8.8	2500	15.0	30	2.77×10^{-3}

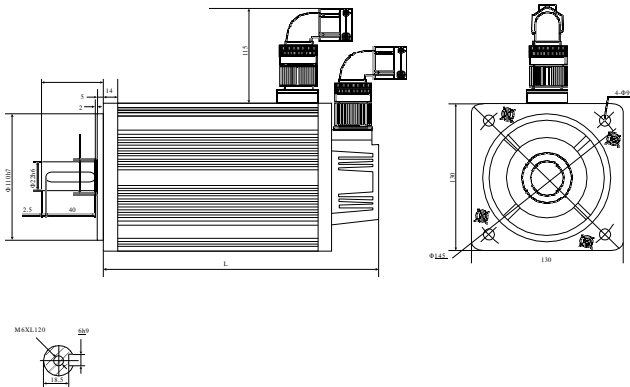

Rated torque(N·M)	130						
	4	5	6	7.7	10		15
					1500rpm	2500rpm	2500rpm
Without Brake size L(mm)	166	171	179	192	213	209	231
With Brake size L(mm)	229	234	242	255	294	290	312

Chapter 9 Motor Adaptation Table

Motor model	Rated power(kW)	Rated line voltage(V)	Rated line Current(A)	Rated speed(rpm)	Rated torque(N·M)	Max rated torque(N·M)	Rotor inertia(Kg·M ²)
EMM-180SP300A15 □□ YYD	3.0	380	7.5	1500	19.0	47	7.0×10 ⁻³
EMM-180SP400A15 □□ YYD	4.0	380	10.0	1500	25.5	62	9.64×10 ⁻³
EMM-180SP450A20 □□ YYD	4.5	380	9.5	2000	21.5	53	7.96×10 ⁻³
EMM-180SP430A15 □□ YYD	4.3	380	10.0	1500	27.0	69	9.64×10 ⁻³
EMM-180SP550A15 □□ YYD	5.5	380	12.0	1500	35.0	70	12.25×10 ⁻³
EMM-180SP750A15 □□ YYD	7.5	380	20.0	1500	48.0	96	16.72×10 ⁻³

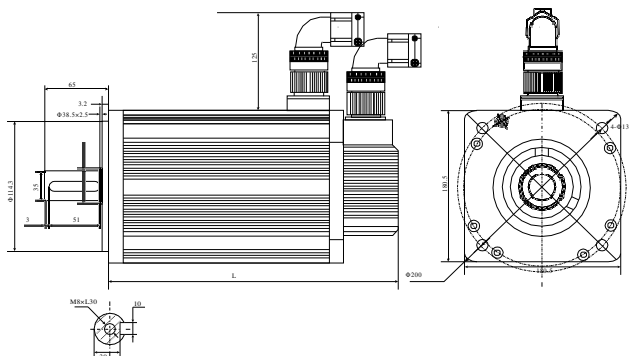

	180					
Rated torque(N·M)	19	21.5	25.5	27	35	48
Without Brake size L(mm)	232	243	262	262	292	346
With Brake size L(mm)	304	315	334	334	364	418

Motor model	Rated power(kW)	Rated line voltage(V)	Rated line Current(A)	Rated speed(rpm)	Rated torque(N·M)	Max rated torque(N·M)	Rotor inertia(Kg·M ²)
EMM-200SP11KA15□□YYD	11	380.0	21	1500	70.0	105	9.77×10 ⁻³
EMM-200SP14KA20□□YYD	14.7	380.0	28	2000	70.0	105	9.77×10 ⁻³
EMM-200SP17KA20□□YYD	17.6	380.0	32	2000	84.0	126	13.08×10 ⁻³

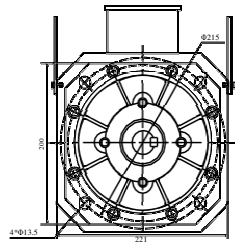
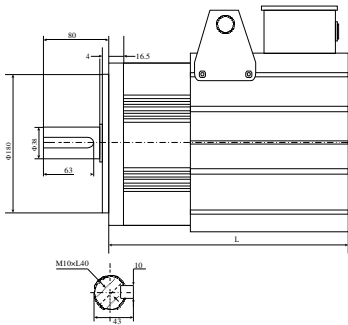

	200	
Rated torque(N·M)	70	84
Without Brake size L(mm)	413	451

Chapter 9 Motor Adaptation Table

Motor model	Rated power(kW)	Rated line voltage(V)	Rated line Current(A)	Rated speed(rpm)	Rated torque(N·M)	Max rated torque(N·M)	Rotor inertia(Kg·M ²)
EMM90KP073A20□YYB	0.7	220	3.0	2000	3.5	10.5	3.4×10^{-4}
EMM-90KP100A25□YYB	1.0	220	4.0	2500	4.0	12	3.7×10^{-4}

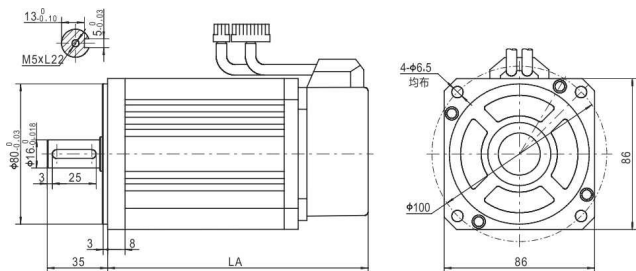

	90	
Rated torque(N·M)	3.5	4
Without Brake size L(mm)	172	182
With Brake size L(mm)	214	224

Motor model	Rated power(kW)	Rated line voltage(V)	Rated line Current(A)	Rated speed(rpm)	Rated torque(N·M)	Max rated torque(N·M)	Rotor inertia(Kg·M ²)
EMM-110KP120A30□YYB	1.2	220	5.0	3000	4.0	12	5.4×10^{-4}
EMM-110KP180A30□YYB	1.8	220	6.0	3000	6.0	18	7.6×10^{-4}

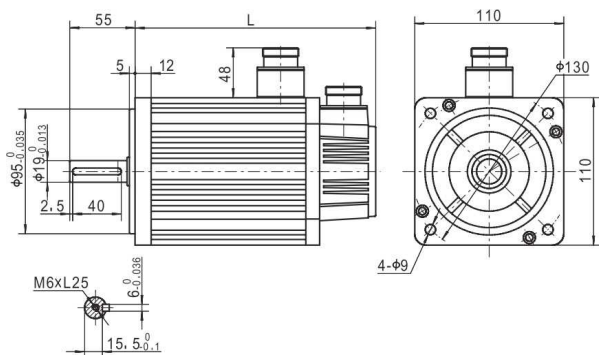

	110	
Rated torque(N·M)	4	6
Without Brake size L(mm)	189	219
With Brake size L(mm)	254	284

Chapter 10 Appendices

10.1 Standard wiring of control mode

10.1.1 Speed control mode

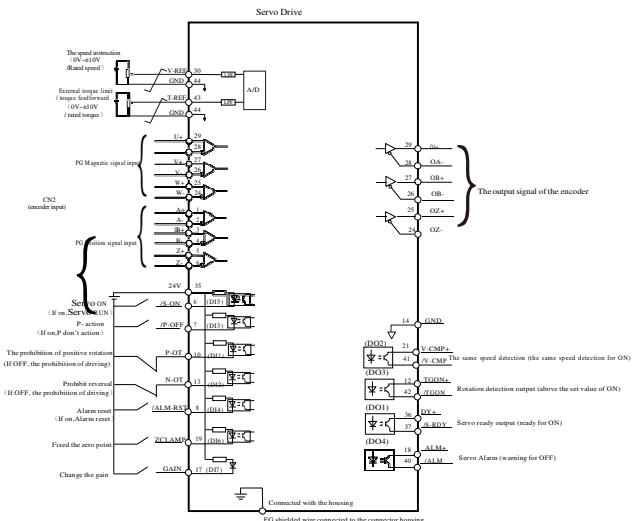

10.1.2 Location control mode

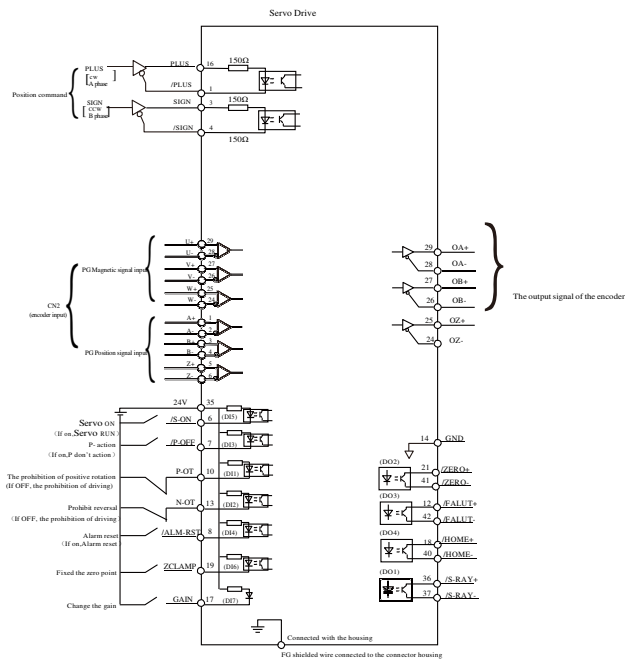

10.1.3 Torque control mode

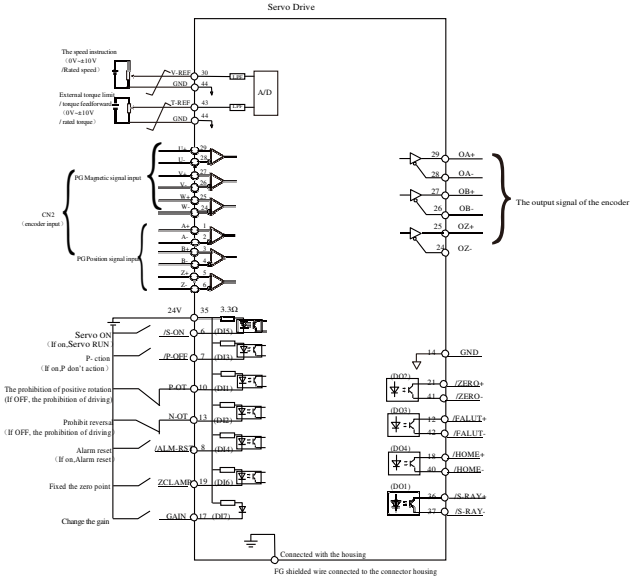

10.2 Wiring port definition(200W-3kW)

10.2.1 Strong power terminals instructions

Terminal symbol	Signal Name	Function
L1	The main circuit power input single-phase or three-phase interface terminal	187V - 242V(-15% ~ 10%) 50/60Hz The maximum inrush current is 20A.
L2		
L3		
U	Servo motor connection terminals	Connect correspondingly to servo motor's U, V, W
V		
W		
L1C	The control circuit power input terminal	Single-phase AC200V ~ 230V (-15 ~ +10%) 50Hz/60Hz
L2C		
B	External regenerative resistor connection terminals	Server built-in regenerative resistor, so the factory must disconnect between B-P, insufficient regeneration ,connect an external regenerative resistor between B-P.Please purchase external regeneration resistor separately.
P		

10.2.2 Input and output signal connection (CON1) terminal definition

Pin number of interface terminal	Signal Name	Function Description	Pin number of interface terminal	Signal Name	Function Description
1	/PULS	Instruction pulse input -	2	PULLHI	Instruction symbol outside source's input interface
3	SIGN+LV	Instruction symbol input +5V	4	/SIGN	Instruction symbol input -
5	OCZ	Encoder zero output	6	DI5-	Digital signal 5 input -
7	DI3-	Digital signal 3 input -	8	DI4-	Digital signal 4 input -
9	COM-	Interior 24V power gnd	10	DI1-	Digital signal 1 input -
11	DI9-	Digital signal 9 input -	12	DO3+	Digital signal 3 output +
13	DI2-	Digital signal 2 input -	14	GND	Common ground
15	+24V	Interior 24V power positive	16	PULS+LV	Instruction pulse input +5V
17	DI7-	Digital signal 7 input -	18	DO5+	Digital signal 5 output +
19	DI6-	Digital signal 6 input -	20	HSIGN+	High speed pulse instruction symbol input +

21	DO4+	Digital signal 4 output +	22	DO2+	Digital signal 2 output +
23	DO2-	Digital signal 2 output -	24	PZO-	PG frequency division output Z signal-
25	PZO+	PG frequency division output Z signal +	26	PBO-	PG frequency division output B signal-
27	PBO+	PG frequency division output B signal +	28	PAO-	PG frequency division output A signal-
29	PAO+	PG frequency division output A signal+	30	AI2	Analog 2 input
31	PULLHI	Open-collector output interior 24V	32	HPULSE-	High speed pulse instruction input -
33	HPULSE+	High speed pulse instruction input +	34	HSIGN-	High speed pulse instruction symbol input -
35	COM+	External+24V	36	DO1+	Digital signal 1 output +
37	DO1-	Digital signal 1 output -	38	+5V	5V power+
39	DI8-	Digital signal 8 input -	40	DO5-	Digital signal 5 output -
41	DO4-	Digital signal 4 output -	42	DO3-	Digital signal 3 output -
43	AI1	Analog 1 input	44	GND	Common ground

(NOTE)Please make input and output signals connect to the connector with cable shielding,Servo unit side connects to the FG (frame ground)

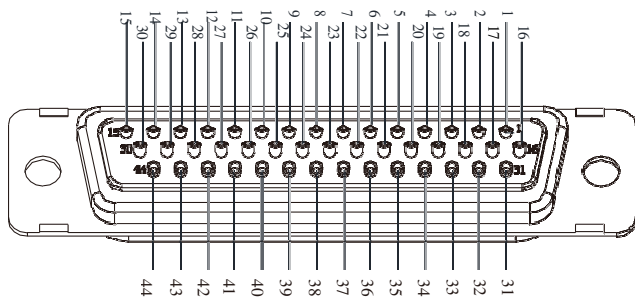

10.2.3 Feedback signal connection (CN2) terminal definition

10.2.3.1 Provincial line increment encoder interface definition

Pin number of interface terminal	Signal name	Function description	Pin number of interface terminal	Signal name	Function description
1	PGA+	Differential signal A input +	2	PGA-	Differential signal A input -
3	PGB+	Differential signal B input +	4	PGB-	Differential signal B input -
5	PGZ+	Differential signal Z input +	6	PGZ-	Differential signal Z input -
7	+5V	5V power	8	GND	Power ground wire
9					

(NOTE)Driver's rotary encoder is DB9 socket

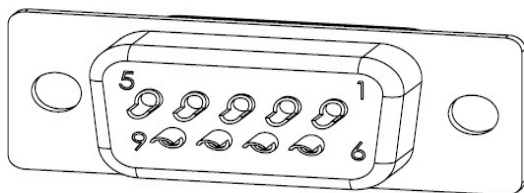

10.2.3.2 Bus-type encoder interface definition

Pin number of interface terminal	Signal name	Function description	Pin number of interface terminal	Signal name	Function description
1	PS+	Bus differential signal input +	2	PS-	Bus differential signal input -
3	NC	NULL	4	NC	NULL
5	NC	NULL	6	NC	NULL
7	+5V	5V power	8	GND	Power ground wire
9					

(NOTE)Driver's rotary encoder is DB9 socket

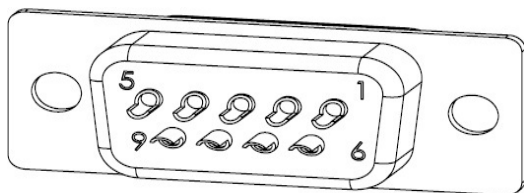

10.2.4 Communication signal connection (CN3) terminal definitions

Pin number of interface terminal	signal name	Function description	Pin number of interface terminal	signal name	Function description
1	RS232R	RS232 receiving line	2	RS232T	RS232 output line
3	RS485+	RS485+ insert	4	RS485-	RS485- insert
5	GND	Ground	6	NC	-
7	NC	-	8	GND	Ground

10.3 Wiring port definition(4.5kW-18.5kW)

10.3.1 Strong power terminals instructions

Terminal symbol	Signal Name	Function
R	The main circuit power input single-phase or three-phase interface terminal	323V - 418V(-15% ~ 10%) 50/60Hz The maximum inrush current is 20A.
S		
T		
U	Servo motor connection terminals	connect correspondingly to servo motor's U, V, W
V		
W		
-	Bus Voltage -	
PB	External regenerative resistor connection terminals	Connect an external regenerative resistor ;
+		

10.3.2 Input and output signal connection (CN1、CN2、CN5)

terminal definition

1) CN1

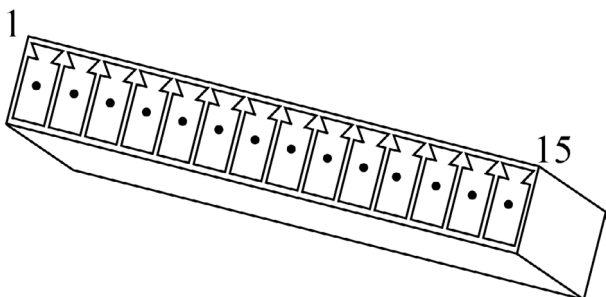

pin number of interface terminal	signal name	Function description	pin number of interface terminal	signal name	Function description
1	COM-	outside 24V power GND	2	DI1	Digital signal 1 input
3	DI2	Digital signal 2 input	4	DI3	Digital signal 3 input
5	DI4	Digital signal 4 input	6	DI5	Digital signal 5 input
7	DI6	Digital signal 6 input	8	DI7	Digital signal 7 input
9	DI8	Digital signal 8 input	10	DI9	Digital signal 9 input
11	COM+	outside 24V power	12	24V+	interior 24V power positive
13	AI1	Analog 1 input	14	GND	GND
15					

2)CN2

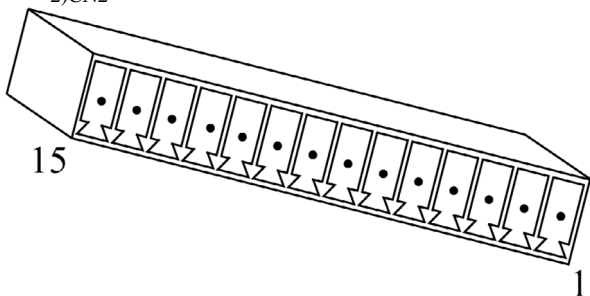

pin number of interface terminal	signal name	Function description	pin number of interface terminal	signal name	Function description
1	SIGN+	Instruction symbol input +	2	SIGN-	Instruction symbol input -
3	PULLHI	Open-collector output interior 24V	4	PULSE+	Instruction pulse input +
5	PULSE-	Instruction pulse input -	6	DO5-	Digital signal 5 output -
7	DO5+	Digital signal 5 output +	8	DO4-	Digital signal 4 output -
9	DO4+	Digital signal 4 output +	10	DO3-	Digital signal 3 output -
11	DO3+	Digital signal 3 output +	12	DO2-	Digital signal 2 output -
13	DO2+	Digital signal 2 output +	14	DO1-	Digital signal 1 output -
15	DO1+	Digital signal 1 output +			

3)CN5

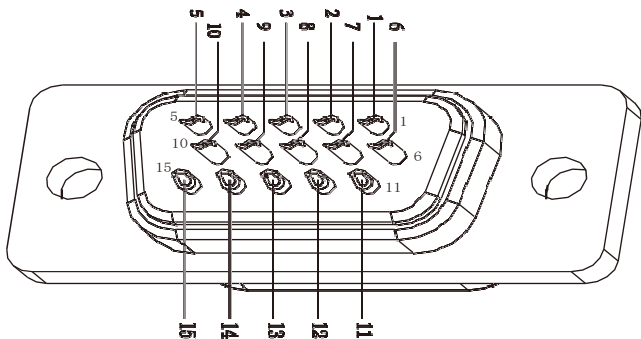

pin number of interface terminal	signal name	Function description	pin number of interface terminal	signal name	Function description
1	HPULSE-	High speed pulse instruction input -	2	HPULSE+	High speed pulse instruction input +
3	HSIGN-	High speed pulse instruction symbol input -	4	HSIGN+	High speed pulse instruction symbol input +
5	GND	GND	6	PAO-	PG frequency division output A signal -

pin number of interface terminal	signal name	Function description	pin number of interface terminal	signal name	Function description
7	PBO-	PG frequency division output B signal -	8	PZO-	PG frequency division output Z signal -
9	NC	Not Connected	10	NC	Not Connected
11	PAO+	PG frequency division output A signal -	12	PBO+	PG frequency division output B signal +
13	PZO+	PG frequency division output Z signal +	14	GND	GND
15	+5V	5V Power			

10.3.3 Feedback signal connection (CN3) terminal definition

Pin number of interface terminal	Signal name	Function description	Pin number of interface terminal	Signal name	Function description
1	PGA+	Differential signal A input +	2	PGA-	Differential signal A input -
3	PGB+	Differential signal B input +	4	PGB-	Differential signal B input -
5	PGZ+	Differential signal Z input +	6	PGZ-	Differential signal Z input -
7	+5V	5V power	8	GND	Power ground wire
9					

Note:Shield wire should be connected to the metal casing.

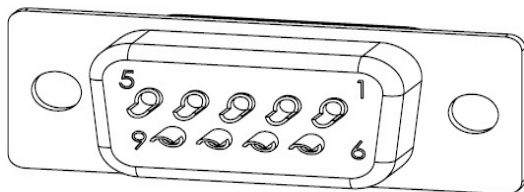

10.3.4 Communication signal connection (CN6、CN7) terminal definitions

Pin number of interface terminal	signal name	Function description	Pin number of interface terminal	signal name	Function description
1	RS232R	RS232 receiving line	2	RS232T	RS232 output line
3	RS485+	RS485+ insert	4	RS485-	RS485- insert
5	GND	Ground	6	CANH	CAN+ insert
7	CANL	CAN- insert	8	GND	Ground

10.4 Connector port circuit

Servo unit's input output signal and the instruction controller's connection example is as follows.

10.4.1 Wiring diagram(200W-3kW)

(1)Instruction input circuit's port.

1.Analog input circuit

CN1 connector's 30-44(the speed instruction input)、43-14(the torque instruction input) terminal

Analog signal is the speed instruction or the torque instruction signal,the input impedance is as follows.

The speed instruction input: about 14 kΩ

The speed command input:about 14 kΩ

The torque instruction input: about 14 kΩ

The input signal's maximum allowable voltage is 12V

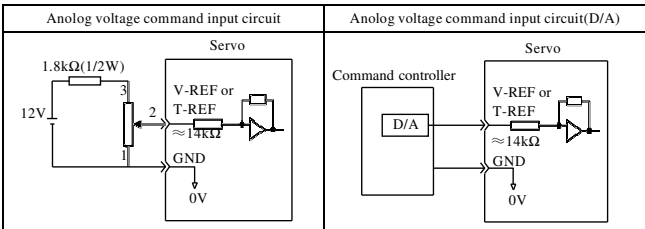

2.Position instruction input circuit

Command controller side's command pulse,offset pulse cleared

signal's output circuit, can output from the bus driver,open collector output (2 kinds).Classification is expressed as follows.

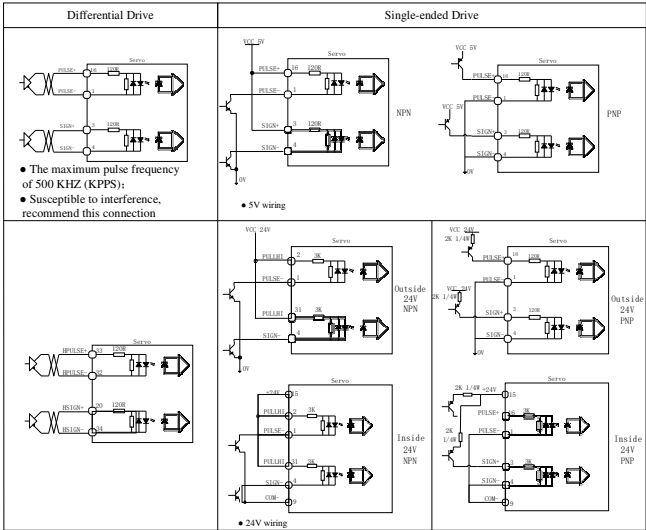

(2) The control input circuit's port

Explain CN1 connector's 32、22、34、36、19、33、18、21、20 terminal.Connected by a relay or open collector transistor circuit.The use of relay connection, select the micro current relay,if don't use the micro current relay,it will lead to poor contact.

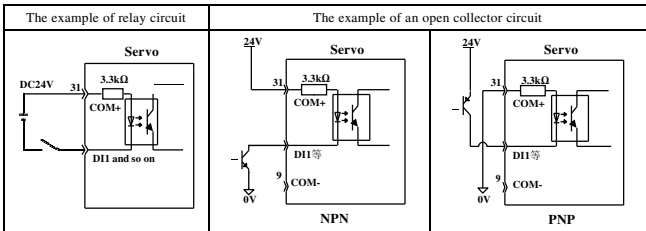

(3) Output circuit's connection port.

Servo unit's signal output circuit has the following 3 kinds.

1.Differential driver output circuit

Following, to explain the CN1 connector's 29-28(A phase signal)、27-26(B phase signal)、25-24(Z phase signal) signals.

Conduct 2 phase (A phase、 B phase) transform output signal (OA+, OA-, OB+, OB-) for the encoder's serial data and the origin of the pulse signal (OZ+, OZ-) is output by the bus driver circuit. In general, use when the servo unit by speed control, constituting position control at the side of command controller. When at the side of command controller, please receive using the bus receiver circuit.

2. Photoelectric encoder's output circuit

Servo alarm (ALM)、 servo ready (/S-RDY) and other output signals related with the output circuit signal, and is connected by the relay or the PLC receiver.

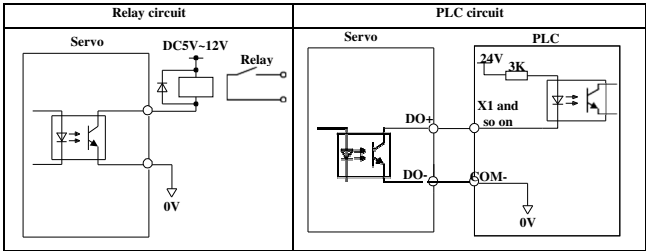

(NOTE) Photoelectric encoder's maximum allowable voltage、 current capacity is as follows.

Maximum voltage: DC30V Maximum current: DC50mA

10.4.2 Wiring diagram (4.5kW-18.5kW)

(1) Instruction input circuit's port.

1. Analog input circuit

CN1 connector's 13-14 (the speed instruction input)、 15-14 (the torque instruction input) terminal

Analog signal is the speed instruction or the torque instruction signal, the input impedance is as follows.

The speed instruction input: about 14 kΩ

The speed command input: about 14 kΩ

The torque instruction input: about 14 kΩ

The input signal's maximum allowable voltage is 12V

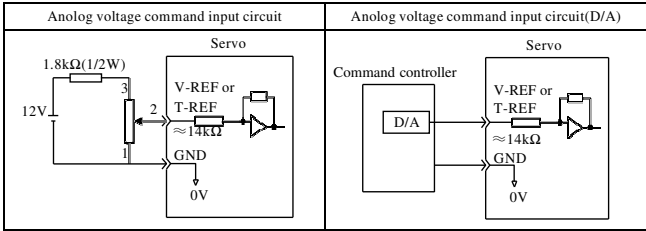

2.Position instruction input circuit

Command controller side's command pulse,offset pulse cleared signal's output circuit, can output from the bus driver,open collector output (2 kinds).Classification is expressed as follows.

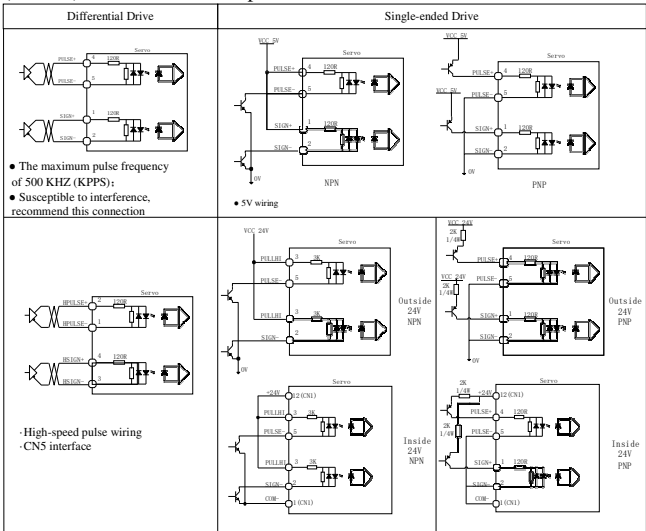

(2) The control input circuit's port

Explain CN1 connector's 2、3、4、5、6、7、9、10 terminal. Connected by a relay or open collector transistor.The use of relay connection, select the micro current relay,if don't use the micro current relay.it will lead to poor contact.

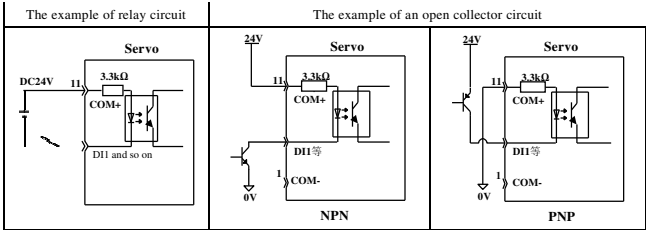

(3) Output circuit's connection port.

Servo unit's signal output circuit has the following 3 kinds.

1. Differential driver output circuit

Following, to explain the CN1 connector's 11-6(A phase signal)、12-7(B phase signal)、13-8(Z phase signal) signals.

Conduct 2 phase (A phase、B phase) transform output signal (OA+, OA-, OB+, OB-) for the encoder's serial data and the origin of the pulse signal (OZ+, OZ-) is output by the bus driver circuit. In general, use when the servo unit by speed control, constituting position control at the side of command controller. When at the side of command controller, please receive using the bus receiver circuit.

2. Photoelectric encoder's output circuit

Servo alarm (ALM)、servo ready (/S-RDY) and other output signals related with the output circuit signal, and is connected by the relay or the PLC receiver.

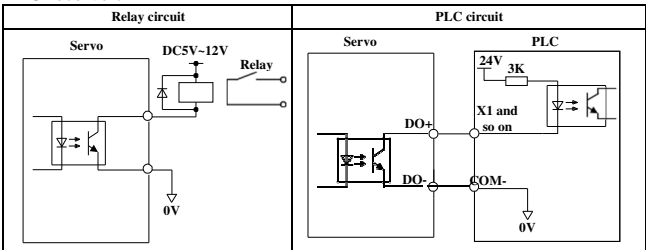

(NOTE) Photoelectric encoder's maximum allowable voltage、current capacity is as follows.

Maximum voltage: DC30V Maximum current: DC50mA

Recommended external braking resistor

Model	Input voltage/ current	Output voltage/ current	I _{max}	Built-in resistance	External resistance minimum	Recommended value
EMD100-40A-2	1PH 5.5A 220VAC	3PH 2.8A 0~200VAC	20A	90Ω/50W		
EMD100-75A-2	1PH 10.9A 220VAC	3PH 5.5A 0~200VAC	20A	90Ω/50W		
EMD100-100A-2	3PH 8.7A 220VAC	3PH 7.6A 0~200VAC	40A	30Ω/120W		
	1PH 15.1A 220VAC					
EMD100-150A-2	3PH 11A 220VAC	3PH 9.6A 0~200VAC	40A	30Ω/120W		
	1PH 19.1A 220VAC					
EMD100-200A-2	3PH 13.3A 220VAC	3PH 11.6A 0~200VAC	40A	30Ω/120W		
	1PH 23.1A 220VAC					
EMD100-300A-2	3PH 17.2A 220VAC	3PH 15A 0~200VAC	25A		>25Ω	30Ω/300W
	1PH 28.2A 220VAC					
EMD100-200A-4	3PH 6.9A 380VAC	3PH 6.0A 0~200VAC	15A		>50Ω	100Ω/300W
EMD100-300A-4	3PH 10.3A 380VAC	3PH 9.0A 0~200VAC	15A		>50Ω	100Ω/300W
EMD100-450A-4	3PH 14.8A 380VAC	3PH 12.9A 0~200VAC	25A		>30Ω	50Ω/500W
EMD100-550A-4	3PH 18.9A 380VAC	3PH 16.5A 0~360VAC	25A		>30Ω	40Ω/600W
EMD100-750A-4	3PH 29.5A 380VAC	3PH 25.7A 0~360VAC	50A		>15Ω	25Ω/1000W
EMD100-11kA-4	3PH 37.8A 380VAC	3PH 33.0A 0~360VAC	50A		>15Ω	25Ω/1000W
EMD100-15kA-4	3PH 51.7A 380VAC	3PH 45A 0~360VAC	100A		>10Ω	20Ω/1200W
EMD100-18kA-4	3PH 57.5A 380VAC	3PH 50A 0~360VAC	100A		>10Ω	20Ω/1200W

